

# 3arm<sup>+</sup>®

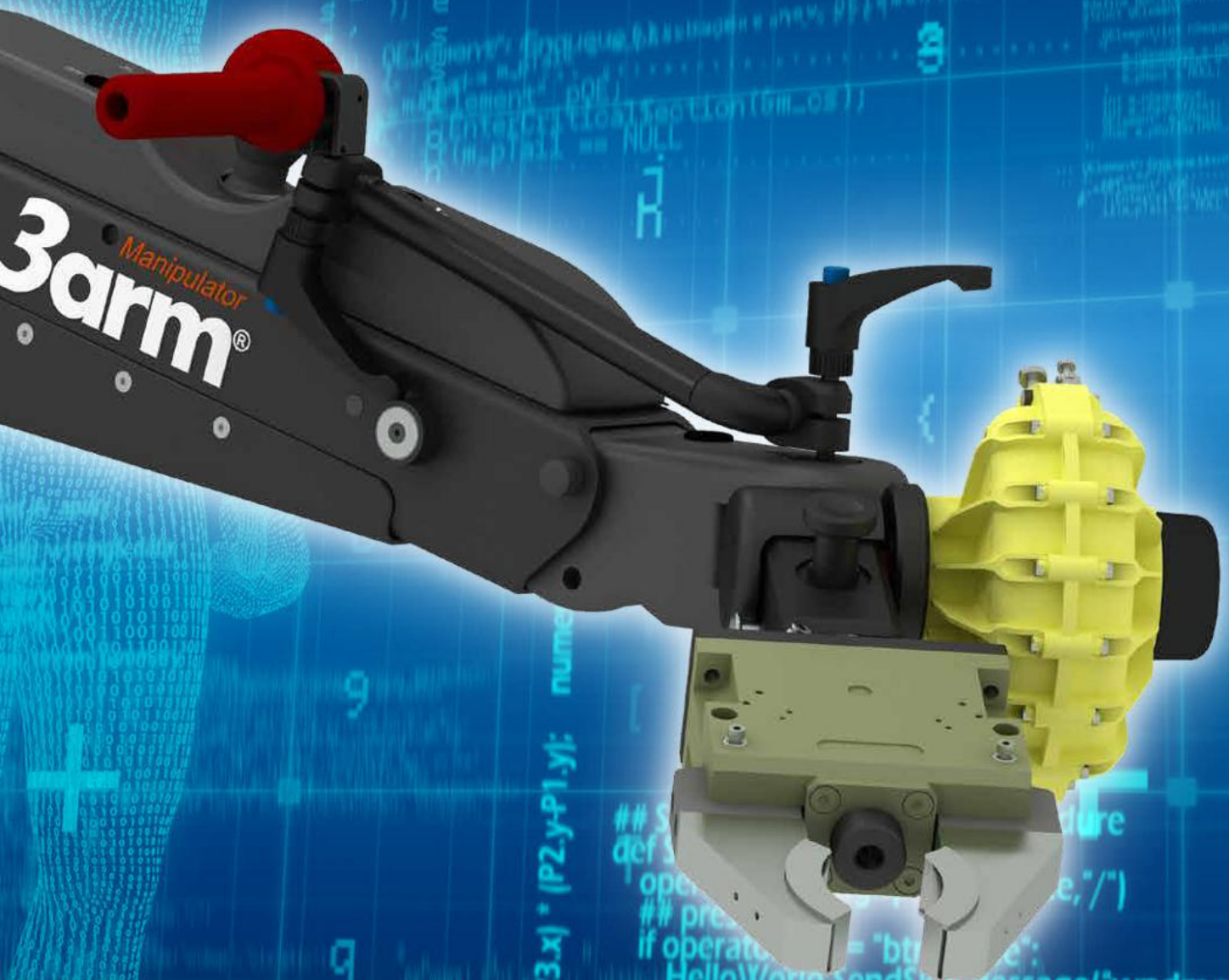

**MANIPULATOR M5**

**ERGONOMIC SOLUTIONS**



**3arm**<sup>®</sup> is a division of the Tecnospiro Machine Tool Company located in Sant Joan de Vilatorrada a small village about 40 miles west of Barcelona. They are a small family owned company that has been in business since the 60's. They have a state of the art manufacturing facility and a dynamic engineering staff that has been very innovative in design and inventing new products.

**The 3arm ergonomic arm is the strongest most dependable arm available in the world market place today.** It can be used for assistance in assembly, deburring, off line machining, and all types of lifting operations. Where ever operator fatigue is concern for employee safety, productivity, or quality 3arm has a solution.

**TECNOSPIRO**  
MACHINE TOOL SL

**SAFETY WARNING** 3ARM products are engineered and manufactured with safety in mind. The heat treat specifications exceed or meet all standards. All of the products manufactured by 3ARM are designed to perform without any undue safety issues when caution, common sense and proper safety practices are followed. The use of cutting tools and toolholders is safe when proper application and protection guidelines are observed. Even when these proper precautions are taken, it is possible that fragments of a cutting tool, cutting material, or holding device may be thrown at a very high rate of speed and have potential to cause severe bodily harm. It is imperative that general safety precautions and safety glasses be used at all times.

# 3arm<sup>®</sup> MANIPULATOR M5

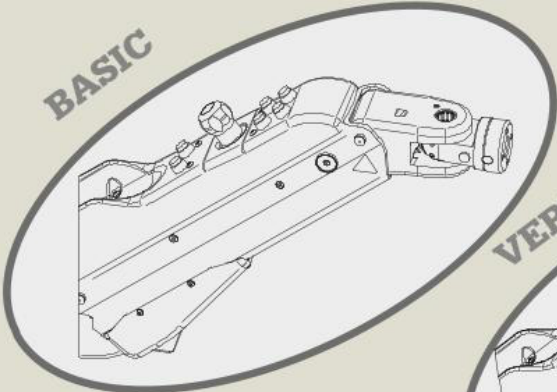

BASIC

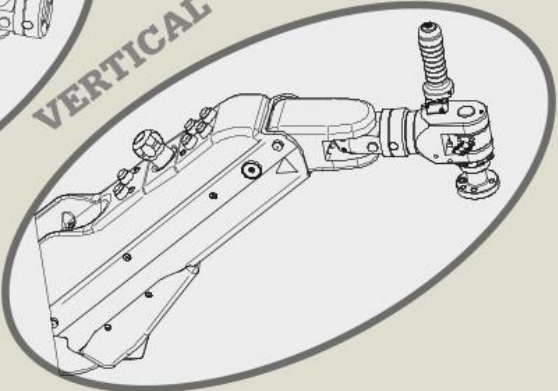

VERTICAL

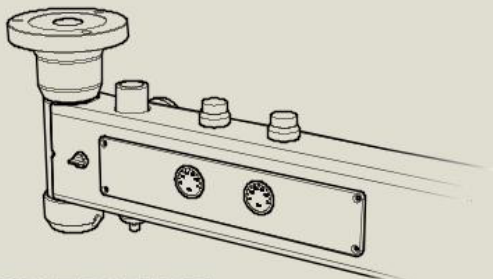

TOP MOUNT

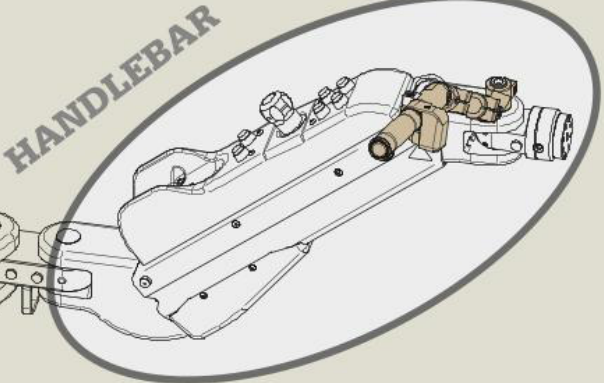

HANDLEBAR

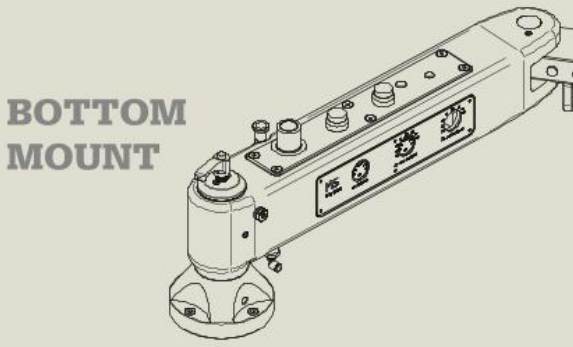

BOTTOM MOUNT

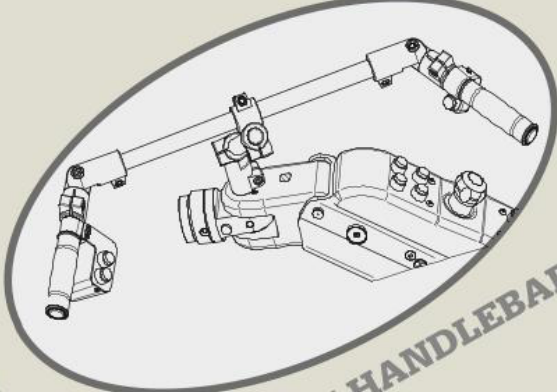

DOUBLE HANDLEBAR

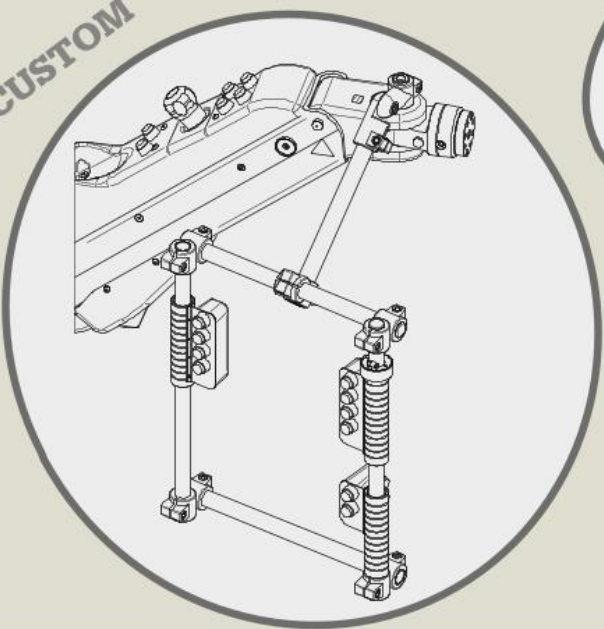

CUSTOM

Head member

HORITZONTAL

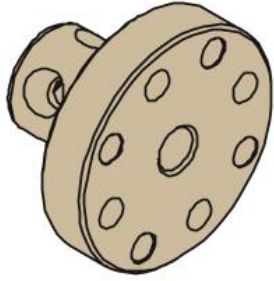

HORITZONTAL  
MAUAL ROTATING

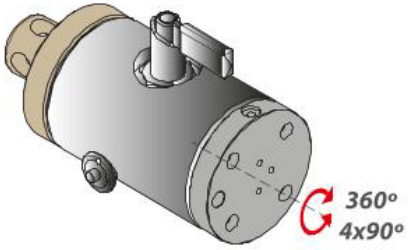

HEAD MEMBER  
REVOLVING

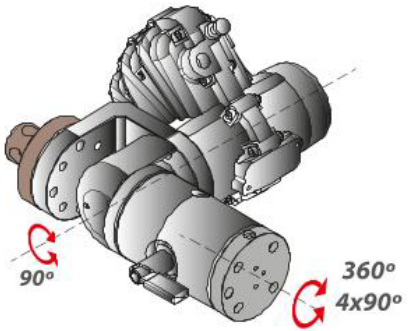

ROTATING

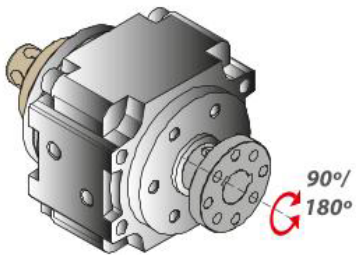

Gripping Systems

GRIPPER

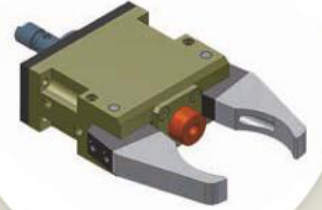

MAGNET



VACUUM



CUSTOMIZED



# M5 with BRAKES

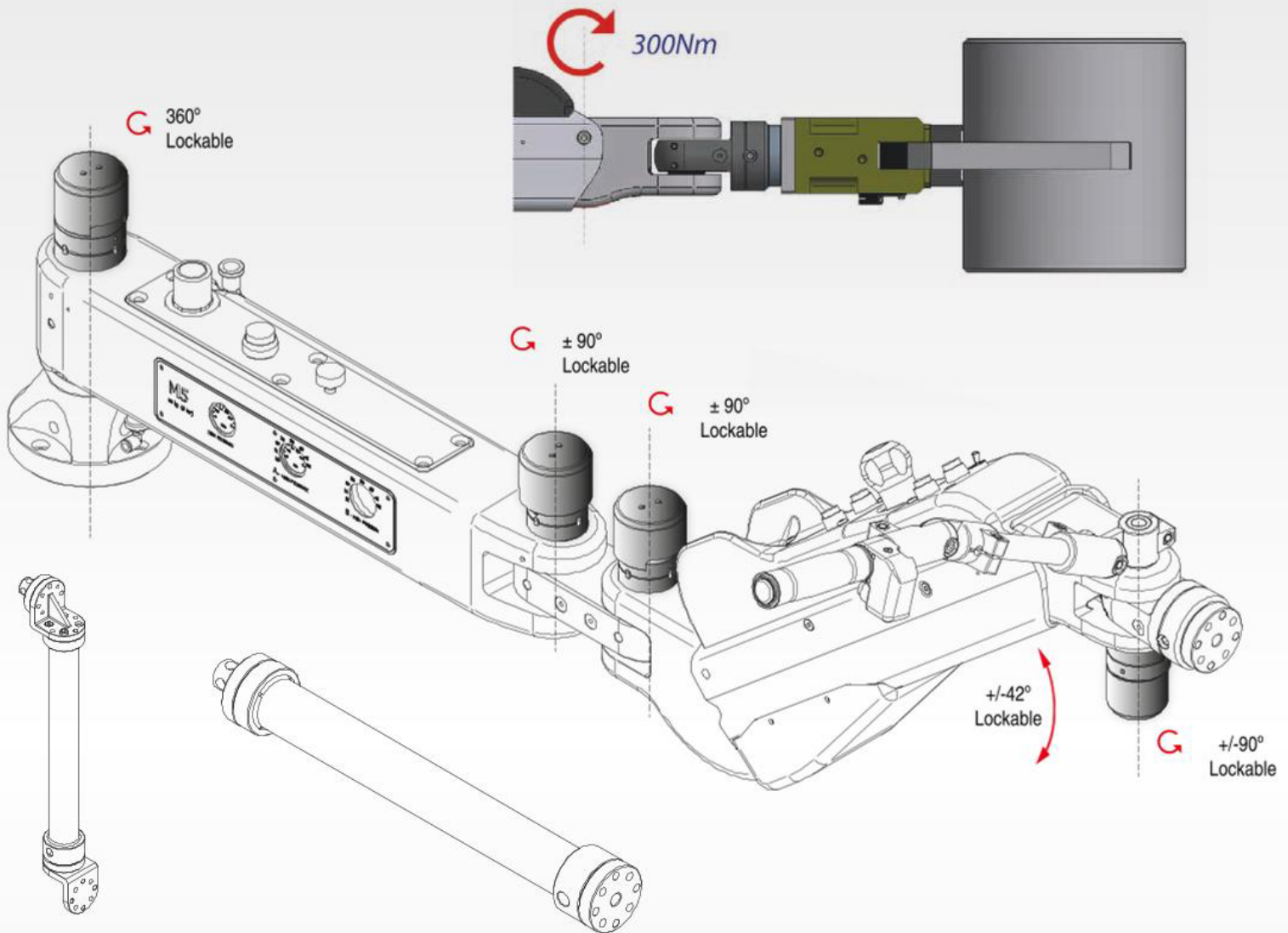

**Manipulator M5** can be equipped with pneumatic brakes to completely lock all the axis of the arm allowing to move and lock in position the part or product to manipulate.

## EXTENSIONS

Depending on the various needs of each application the arm can be supplied with a variety of extensions in order to increase the reach.

# ACCESSORIES

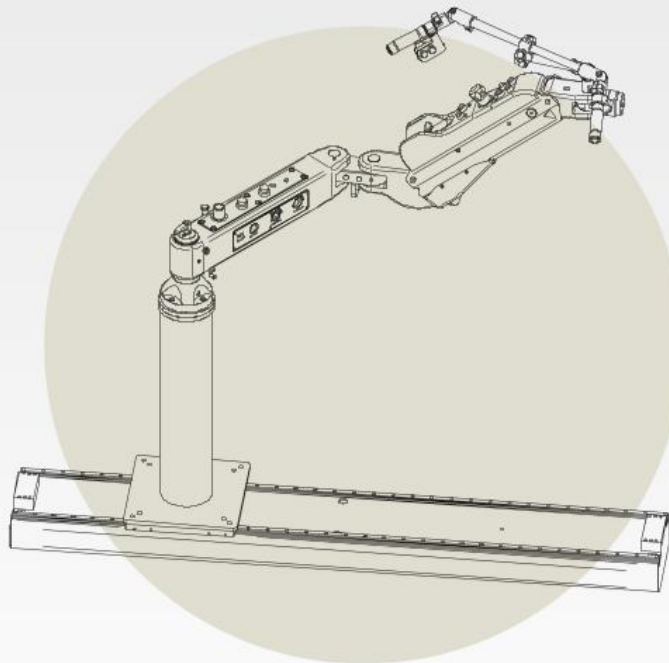

**Floor Rail(2m)+ Column**

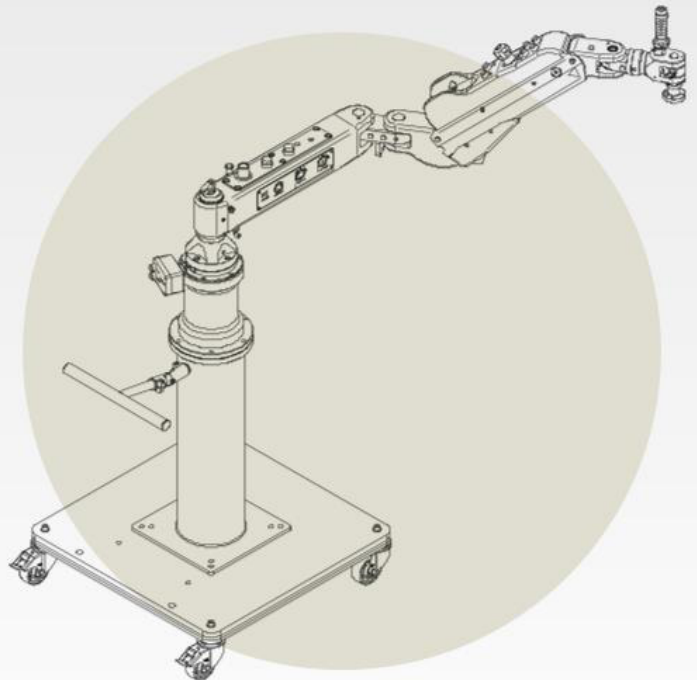

**Trolley+Lifter PNR (500mm)**

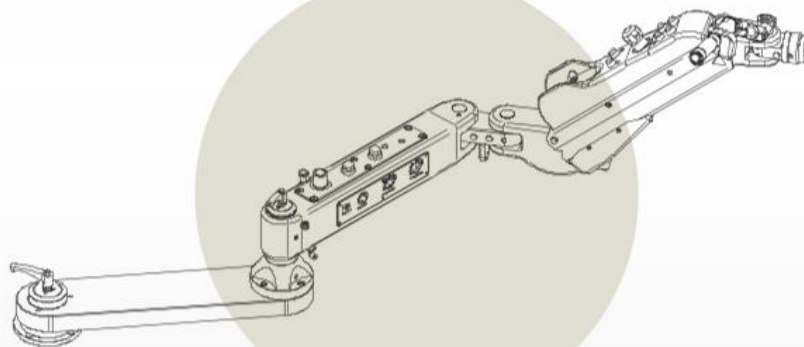

**Radial Extension 600mm (or 1 meter)**

	Extension 600	Extension 1000	Trolley	Fix column	Lifter 500 PNR	Floor rail	Lifter Column 2000
Extension 600			●	●	●	●	●
Extension 1000				●		●	
Trolley	●			●	●	●	●
Fix column	●	●	●		●	●	
Lifter 500 PNR	●		●	●		●	
Floor rail	●	●		●	●		●
Lifter Column 2000	●		●			●	

3arm **Manipulator M5** offers a wide variety of configurations to move parts to and from conveyors, assembly lines, machine tools and much more up to 50 kg.  
 Being the lightest manually controlled load manipulator device with various quick change gripping systems (jaws, vacuum, magnet, hook or custom), the operator can work in excellent ergonomic and safety conditions while gaining an increase in productivity.

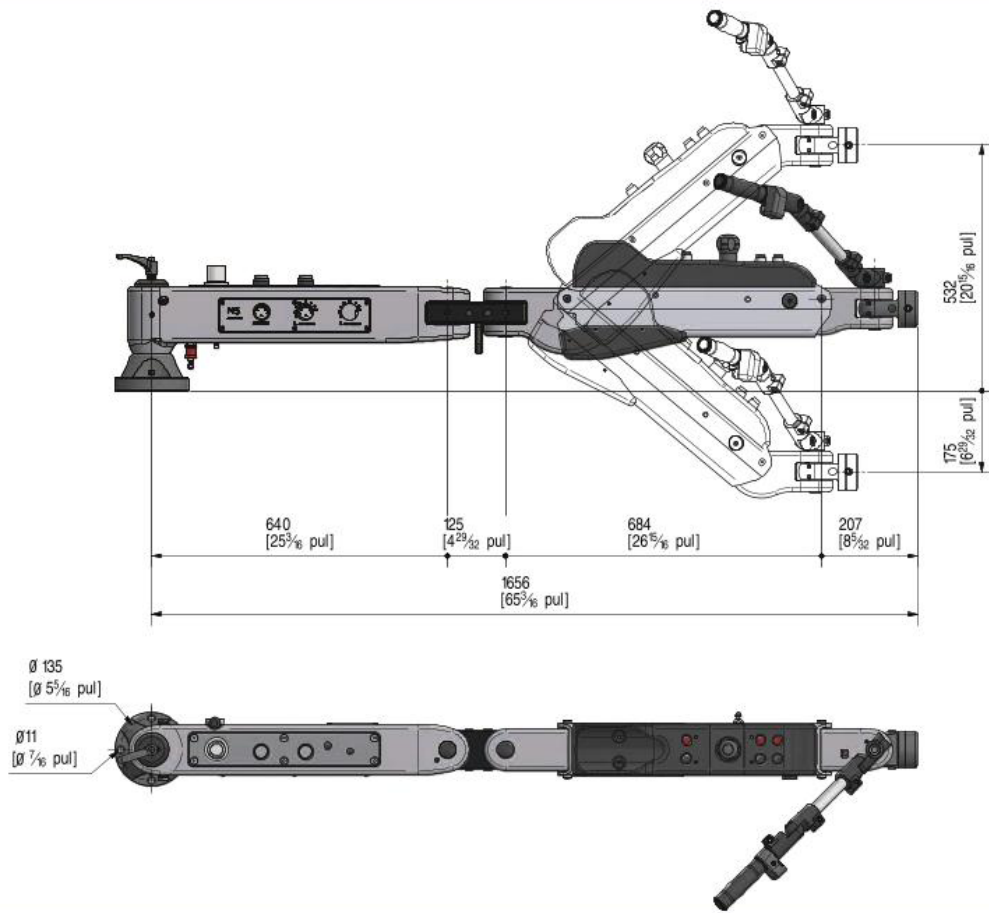

**FEATURES**

Pneumatic specifications	
Supply fluid	Pressurized air
Max. pressure of air supply	0.85 Mpa (8,5 bar)
Max. working pressure	0.8 Mpa (8 bar)
Maximum instantaneous consumption	515 dm <sup>3</sup> /min

Movements	
ZX Plane	± 40°
Working radius in XY plane	1670 mm (65.7")
Z1 Axis	360°
Z2 Axis	180°
Z3 Axis	180°
X Axis	360°/ 4 x 90°
Vertical travel	707 mm (28")

Dimensions and weight	
Height	339 mm (20.4")
Lenght	952 mm (59.1")
Width	262 mm (4.5")
Weight	39 Kg (66 lb)

Working conditions	
Temperature	+15 a +45°C
Relative humidity	Max. 70%
Environment	Indoor industrial settings

Load capacity	
Maximum net load, range	0-50Kg (0-110 lb)
Maximum net load	50 Kg (110 lb)
Maximum gross load (load gripping system + load to be manipulated)	62 Kg (136 lb)

**3arm**<sup>®</sup>  
Handling emotions

**NEW**



## CONNEXALL CO., LTD.

899/50 Moo 21, Soi Chongsiri Parkland, Bangphli-Yai,  
Bangphli, Samutprakarn 10540 Thailand

E-mail : [info@connexall.co.th](mailto:info@connexall.co.th)

Phone : +66-2313-3400

Fax : +66-2313-3402



[www.connexall.co.th](http://www.connexall.co.th)