

AXIS COMPENSATION MODULES

SERIES FGR

▶ PRODUCT ADVANTAGES



▶ Effortless joining process

The ease of movement makes it possible to carry out even the finest joining processes in the shortest amount of time

▶ Single-acting pneumatic cylinder

For easy control and a reduced amount of piping required

▶ Can be fixed in place centrally or de-centrally

For the optimal process sequence, depending on the requirement, you can clamp or centrally lock the equalizer position

4

▶ THE BEST PRODUCT FOR YOUR APPLICATION



▶ Our products welcome the challenge!

Extreme conditions, all over the world—our tried and tested components and systems give you endless possibilities.

Find the best product for your specific use:

www.zimmer-group.com

► BENEFITS IN DETAIL

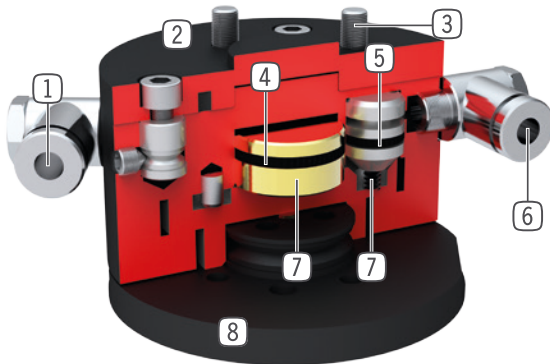

- ① **Energy supply**
- centering
- ② **Robust, lightweight housing**
- Hard-coated aluminum alloy
- ③ **Robot flange**
- partial mounting circle in accordance with EN ISO 9409-1
- ④ **Drive eccentric mounting**
- single-acting pneumatic cylinder with friction disc
- ⑤ **Drive centering**
- three single-acting pneumatic cylinders with cone pistons at 120° distance
- ⑥ **Energy supply**
- eccentric clamping
- ⑦ **Force transfer**
- direct and low-loss via cone/friction disc
- ⑧ **Compensation**
- force-free compensation of position inaccuracies
- up to +/- 4 mm compensating stroke

► FURTHER INFORMATION IS AVAILABLE ONLINE



► Technical Information

All information just a click away at: www.zimmer-group.com

Find data, illustrations, 3D models and operating instructions for your installation size using the order number for your desired product.

Quick, clear and always up-to-date.



AXIS COMPENSATION MODULES

INSTALLATION SIZE FGR1040

▶ PRODUCT SPECIFICATIONS



▶ Forces and moments

Shows static forces and moments which may impact on the compensation module.

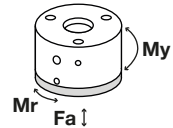

Mr [Nm]	5
My [Nm]	10
Fa [N]	1000

▶ INCLUDED IN DELIVERY



Cylinder Screw

C7984060129

▶ RECOMMENDED ACCESSORIES

Order no.	Technical Data*
Connecting flange according EN ISO 9409-1	TK40
Recommended handling weight [kg]**	10
Horizontal deviation +/- [mm]	2
Rotation angle max. [°]	12
Retention force centred [N]	120
Retention force decentred [N]	50
Operating pressure max. [bar]	8
Operating temperature min. [°C]	5
Operating temperature max. [°C]	+80
Weight [kg]	0.9

*All data measured at 6 bar

**with central attachment

