

2-JAW PARALLEL GRIPPERS WITH LONG STROKE SERIES GEH6000IL

▶ PRODUCT ADVANTAGES



IO-Link

“Highest performance”

- ▶ 5 million maintenance-free cycles
- ▶ Integrated sensing via IO-Link
- ▶ Servo drive with integrated controller

Brushless drive technology, position, speed and force control guarantee the highest amount of functionality

▶ IO-Link on board

In addition to the unshielded single-cable solution, the future-proof, hot-pluggable activation provides you with a wide variety of travel profiles for easy implementation into your control system

▶ Gentle yet powerful

Power version -03 for handling heavy workpieces with mechanical self-locking and version -31 for gently gripping of delicate parts

▶ SERIES CHARACTERISTICS

Installation size	Version	
	-03	-31
GEH60XXIL		
Powerful	●	
Gentle		●
Gripping force adjustable	●	●
High movement speed		●
Integrated sensing	●	●
Positionable	●	●
IO-Link	●	●
Self locking mechanism	●	
5 million maintenance-free cycles (max.)	●	●
IP54	●	●

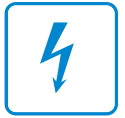

► BENEFITS IN DETAIL

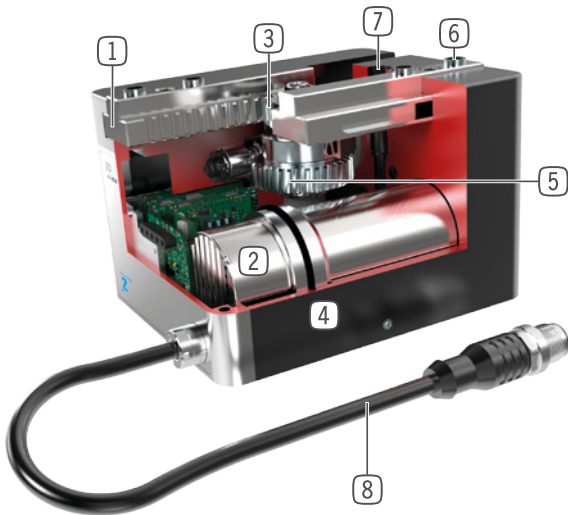

- ① **Precise T-Slot guide**
 - high forces and moments capacity
- ② **Drive**
 - Brushless DC servomotor
- ③ **Rack and pinion gear**
 - synchronized the movement of the gripper jaws
 - high force transfer
- ④ **Robust, lightweight housing**
 - Hard-coated aluminum alloy
- ⑤ **Helical worm gear**
 - self locking mechanism in case of power drop (only version -03)
- ⑥ **Removable centering sleeves**
 - quick and economical positioning of the gripper fingers
- ⑦ **Mounting and positioning**
 - mounting possible from several sides for versatile positioning
- ⑧ **Energy supply**
 - standardized connector

► TECHNICAL DATA

Installation size	Stroke per jaw, adjustable	Gripping force	Weight	IP class
	mm	[N]	[kg]	
GEH6000IL	40 - 60	10 - 1000	0,7 - 0,9	IP54
GEH6100IL	40 - 80	150 - 1800	1,9 - 2,6	IP54

► FURTHER INFORMATION IS AVAILABLE ONLINE



All information just a click away at: www.zimmer-group.com. Find data, illustrations, 3D models and operating instructions for your installation size using the order number for your desired product. Quick, clear and always up-to-date.

2-JAW PARALLEL GRIPPERS WITH LONG STROKE

INSTALLATION SIZE GEH6140IL

▶ PRODUCT SPECIFICATIONS

 **IO-Link**



▶ Gripping force diagram

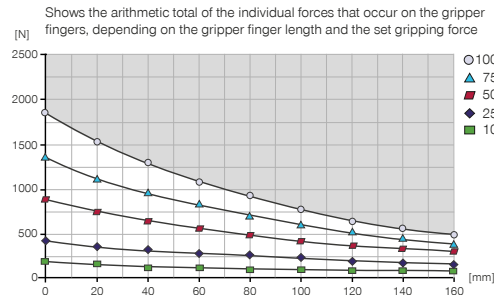

▶ Forces and moments

Displays static forces and moments that can also have an effect, besides the gripping force.

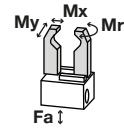

Mr [Nm]	70
Mx [Nm]	80
My [Nm]	60
Fa [N]	1500

▶ INCLUDED IN DELIVERY



4 [piece]
Centering Disc
DST70000

▶ YOU CAN FIND RECOMMENDED ACCESSORIES ON THE FOLLOWING PAGES

Order no.	▶ Technical data
	GEH6140IL-03-B
Control	🔗 IO-Link
Drive	BLDC motor
Stroke per jaw, adjustable [mm]	40
Nominal gripping force [N]	1800
Gripping force min. [N]	150
Current consumption max. [A]	5
Self locking mechanism	mechanical
Permissible weight per jaw max [kg]	1
Length of the gripper fingers max. [mm]	160
Max. movement speed per gripper finger [mm/s]	50
Repetition accuracy +/- [mm]	0.02
Operating temperature min. [°C]	5
Operating temperature max. [°C]	+50
Protection to IEC 60529	IP54
Weight [kg]	1.9

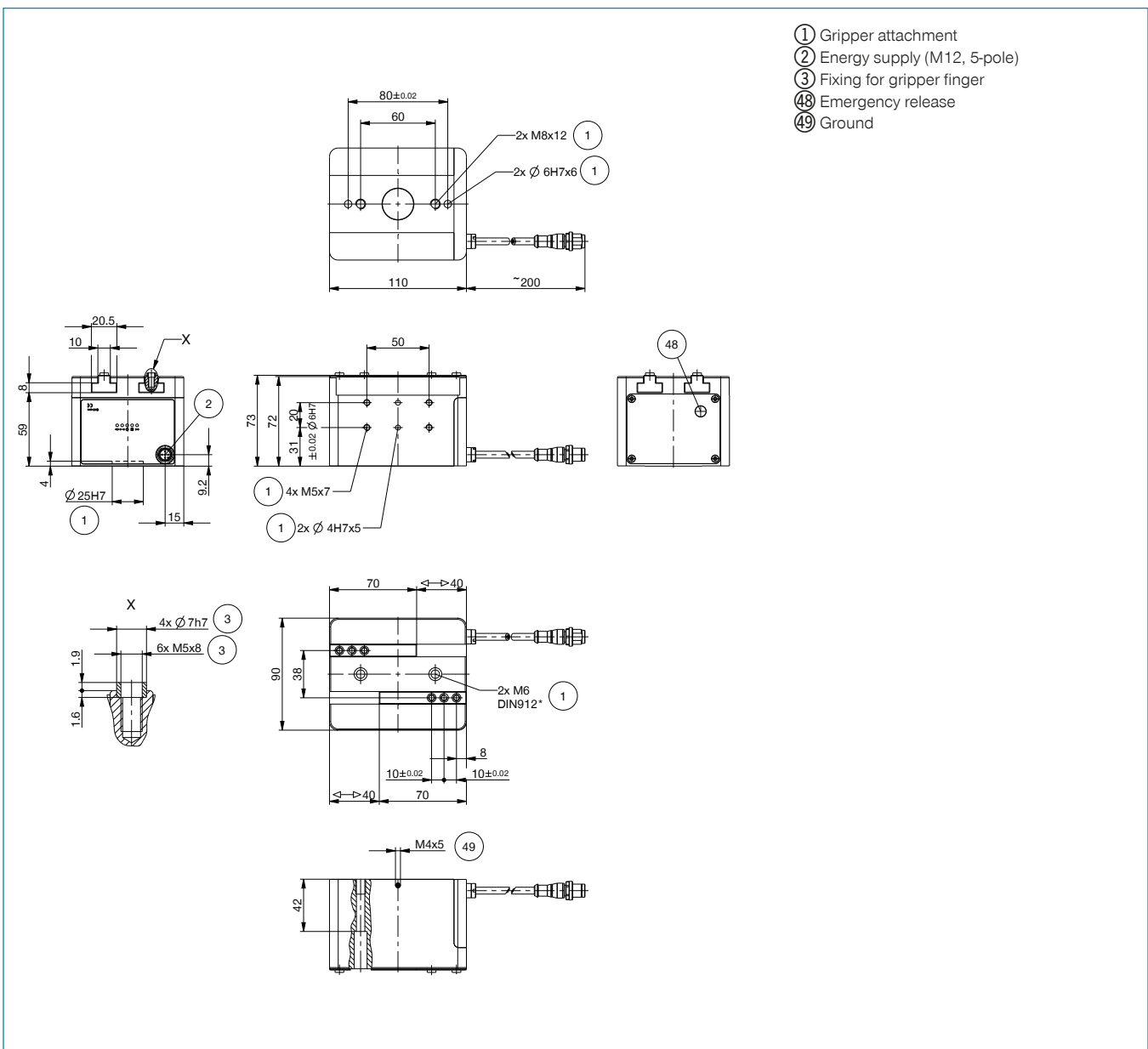

2-JAW PARALLEL GRIPPERS WITH LONG STROKE SERIES GEH6000IL - ACCESSORIES

▶ ACCESORIES



▶ RECOMMENDED ACCESSORIES GEH6000IL

Pos.	Order no.	Accessories
①	UB5006AL	* Universal jaw aluminium
①	UB5006ST	* Universal jaw steel
②	WB5006L	* Changeable jaw, loose-part-set
③	WB5006F	* Changeable jaw, fix-part
④	EB5006ST	* Steel adjustment jaw
④	EB5006AL	* Aluminum adjustment jaw

*in conjunction with pos. ⑤

Pos.	Order no.	Accessories
⑤	APGEH6000	Adapter plate
⑥	UB6000-B	Universal jaw set aluminium
⑦	KAG500IL	Plug-in connector straight 5 m - plug, socket M12
⑧	B12-Y-5IL	Y-Plug-in Connector
⑨	SCM-C-00-00-A	Smart Communication Module

▶ RECOMMENDED ACCESSORIES GEH6100IL

Pos.	Order no.	Accessories
①	UB5008AL	* Universal jaw aluminium
①	UB5008ST	* Universal jaw steel
②	WB5008L	* Changeable jaw, loose-part-set
③	WB5008F	* Changeable jaw, fix-part
④	EB5008ST	* Steel adjustment jaw
④	EB5008AL	* Aluminum adjustment jaw

*in conjunction with pos. ⑤

Pos.	Order no.	Accessories
⑤	APGEH6100	Adapter plate
⑥	UB6100-B	Universal jaw set aluminium
⑦	KAG500IL	Plug-in connector straight 5 m - plug, socket M12
⑧	B12-Y-5IL	Y-Plug-in Connector
⑨	SCM-C-00-00-A	Smart Communication Module

2-JAW PARALLEL GRIPPERS WITH LONG STROKE SERIES GEH6000IL FUNCTIONAL DESCRIPTION



GRIPPING COMPONENTS

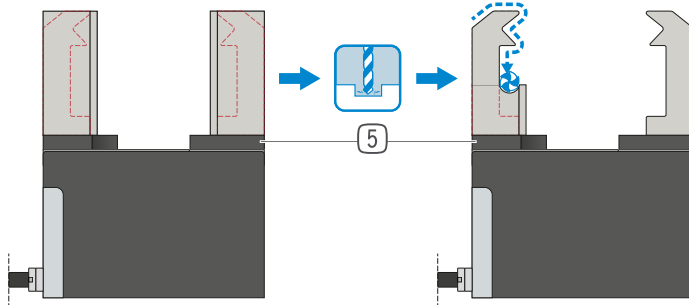

Universal jaws – UB5000

Can be used immediately or for individual reprocessing

The gripper blanks are available in aluminum (AL) and steel (ST) versions and are installed directly on the gripper using the screws in the scope of delivery. The fits for the centering sleeves are already in place for this purpose. One universal jaw is required for each gripper jaw.

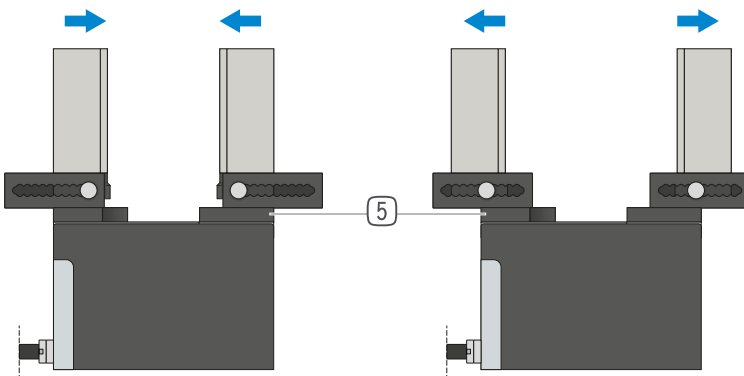

Adjustment jaws – EB5000

For tool-free adaptation of the gripper range

By manually activating the locking mechanism, which is pre-tensioned by a spring, the adjustment jaw can be moved within a grid of detent notches that has a number scale. Depending on the forces and torques that apply, the adjustment jaws are available in aluminum (AL) and steel (ST) versions. One adjustment jaw is required for each gripper jaw.

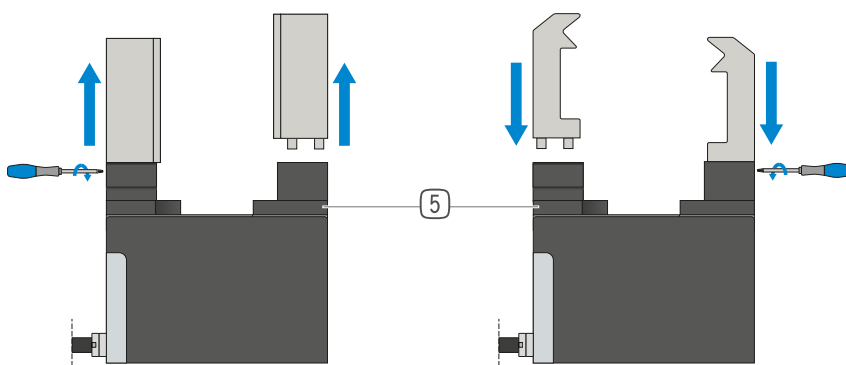

Interchangeable jaws – WB5000

Enable fast change of individual gripper fingers

For each gripper jaw, a fixed part and at least one loose part set is needed, depending on the number of gripper fingers to be changed. Manual locking via the Torx wrench included in the scope of delivery of the fixed part can take place from two sides.



THE GRIPPING COMPONENTS CAN BE COMBINED!

The gripping components listed above can be combined with each other. For connection to the gripper, the adapter plate (5), which is included in the recommended accessories for the gripper, is required.



GRIPPING COMPONENTS

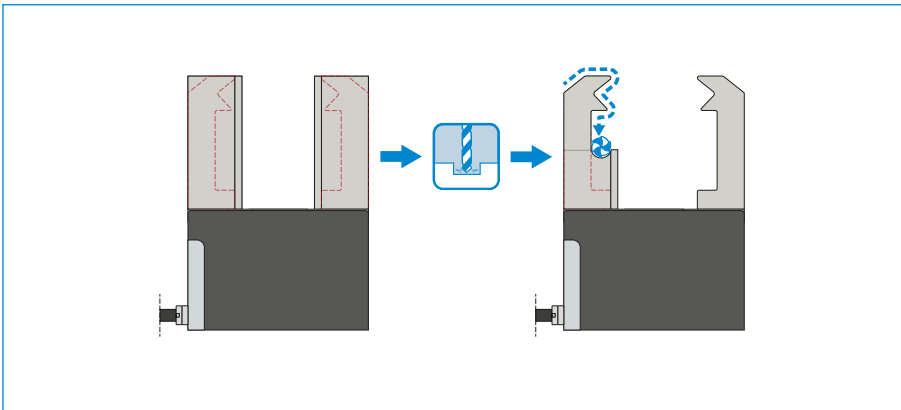

Universal jaws – UB6000-B

Can be used immediately or for individual reprocessing

The gripper blanks are available in an aluminum (AL) version and are installed directly on the gripper using the screws in the scope of delivery. The fits for the centering sleeves are already in place for this purpose. One universal jaw set is required for each gripper.



CONNECTIONS / OTHER

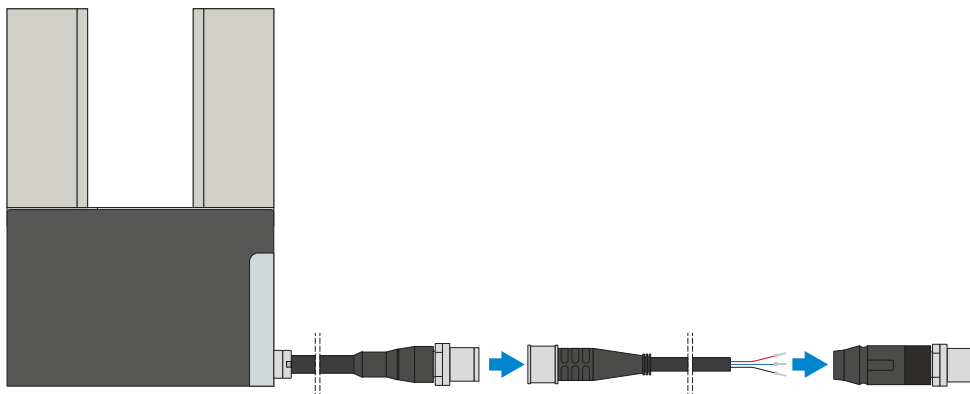

Plug-in connectors

For extending and fabricating the connection lines

Cables with a length of 10 m with exposed leads are available. Depending on the specific needs, the cables can be shortened or fabricated with connectors in sizes M12. A 5 m long cable with connector / socket is available for the IO-Link connection.

2-JAW PARALLEL GRIPPERS WITH LONG STROKE SERIES GEH6000IL FUNCTIONAL DESCRIPTION



CONNECTIONS / OTHER

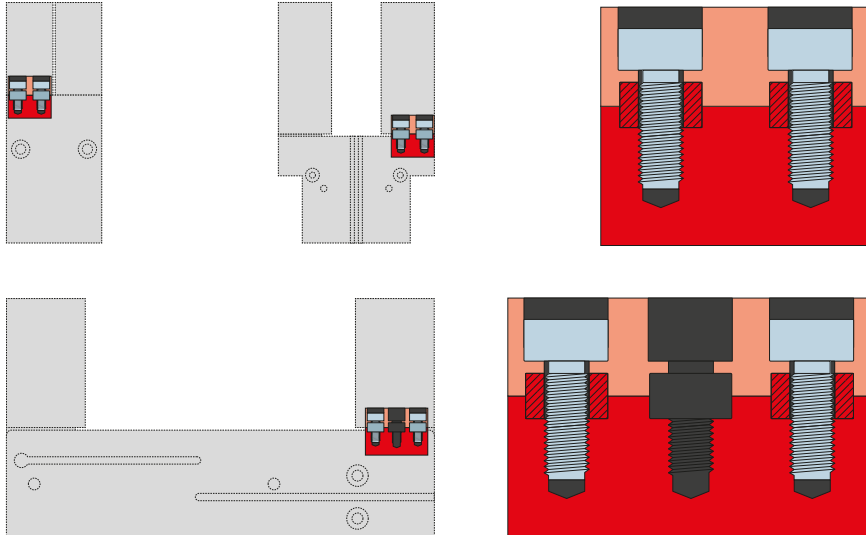

Centering sleeves

For defined position measurement of the gripper fingers

The centering sleeves are inserted into the fits of the gripper jaws to define the position of the gripper fingers. The centering sleeves are comparable to a pin connection.

2-JAW PARALLEL GRIPPERS WITH LONG STROKE SERIES GEH6000IL GRIPPER FINGER LENGTH



MAXIMUM GRIPPER FINGER LENGTH

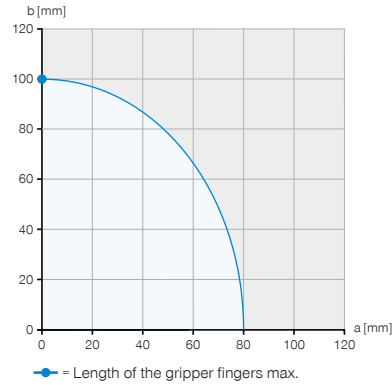
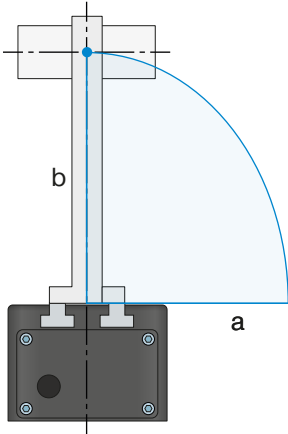

Example 1

Vertical force application point

$a = 0 \text{ mm}$

$b = 100 \text{ mm}$

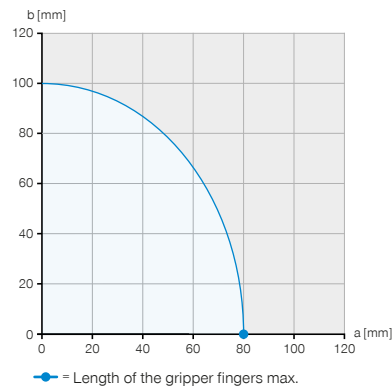
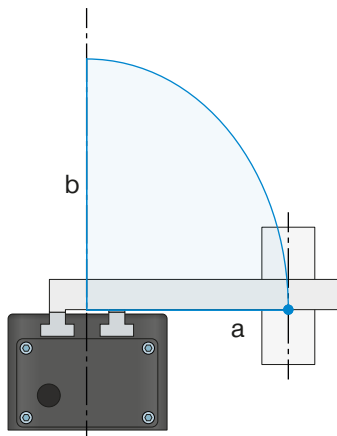

Example 2

Horizontal force application point

$a = 80 \text{ mm}$

$b = 0 \text{ mm}$

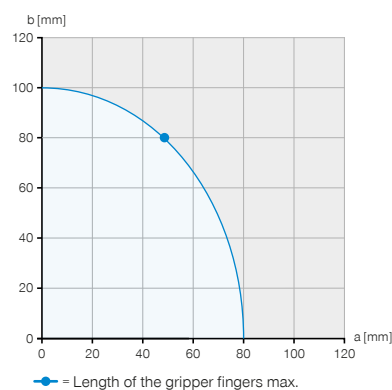
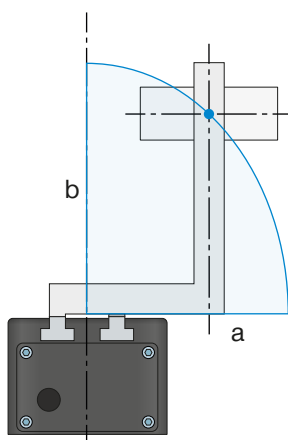

Example 3

Maximum permissible projection

$a = 48 \text{ mm}$

$b = 80 \text{ mm}$

The examples show the maximum horizontal (a) and vertical (b) gripper finger length using the example of a GEH6060IL-03-B, which is represented by the blue area.



GRIPPING FORCE AS A FUNCTION OF GRIPPER FINGER LENGTH

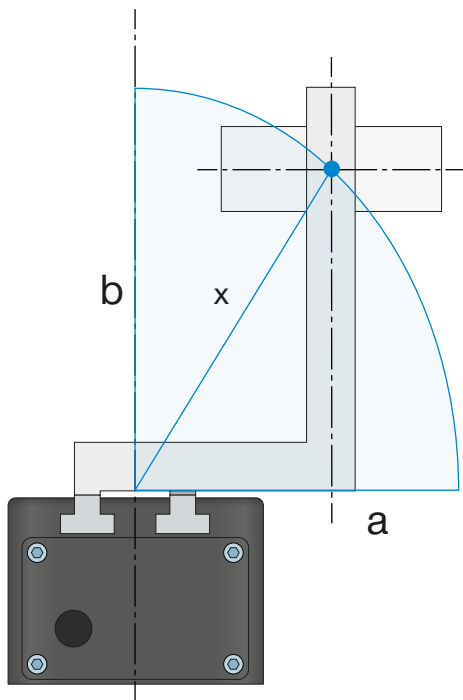

► Gripping force diagram

Shows the arithmetic total of the individual forces that occur on the gripper fingers, depending on the gripper finger length and the set gripping force

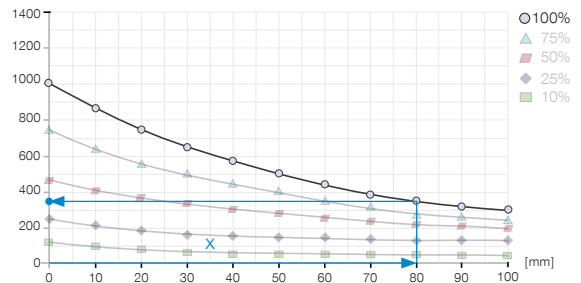

Example 4

Resulting gripper finger length for determining the gripping force

a = 55 mm

b = 58 mm

$$x = \sqrt{55^2 + 58^2} = 80 \Rightarrow 350 \text{ N}$$



The specified maximum gripper jaw length in the gripper technical data refers to a vertical (b) alignment of the gripper jaws. With a horizontal (a) overhang, the maximum gripper jaw length is reduced accordingly. The table shows the maximum gripper jaw lengths of the individual sizes.

► TECHNICAL DATA

Installation size	Permissible weight per jaw max	Length of the gripper fingers max. vertical (b)	Length of the gripper fingers max. horizontal (a)
	[kg]	[mm]	[mm]
GEH6000IL	0.3	100	80
GEH6100IL	1	160	130

SECURED CONFIGURATION EXAMPLES

GEH6000IL SERIES

▶ GEH6000IL (IO-LINK) WIRING TO CONTROL CABINET (BECKHOFF)

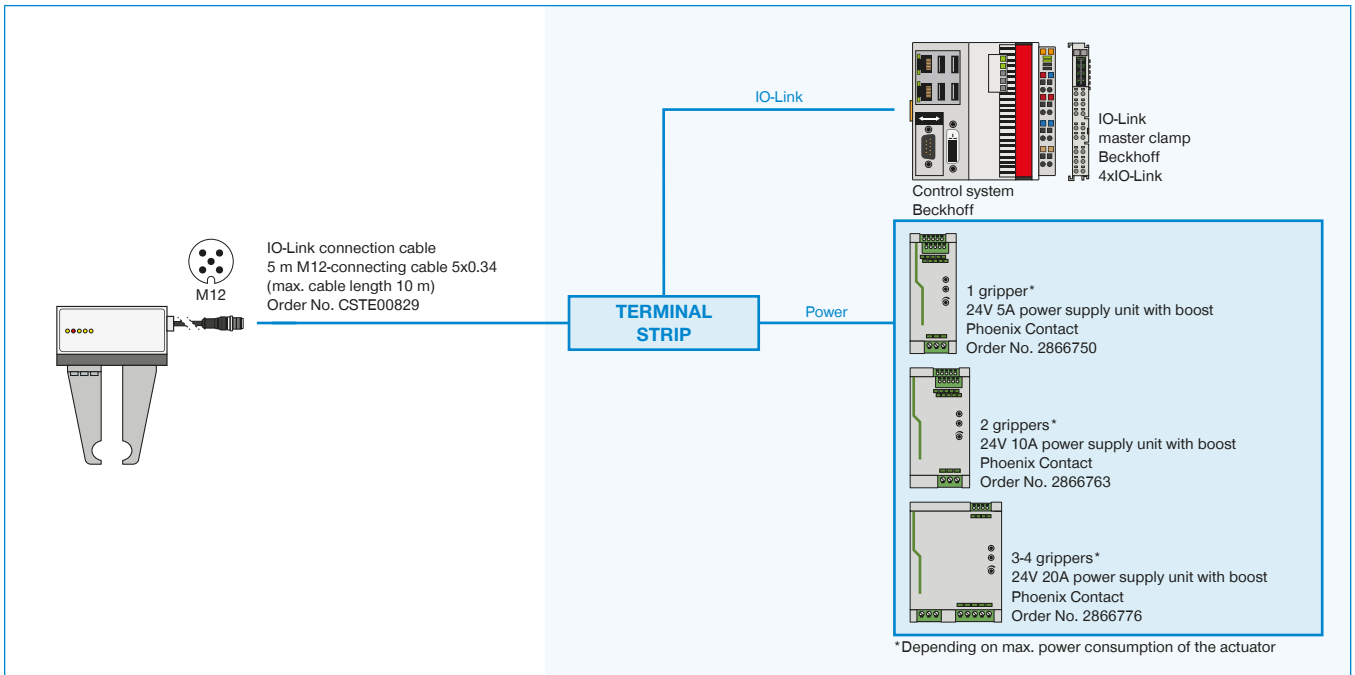

▶ GEH6000IL (IO-LINK) WIRING TO CONTROL CABINET (SIEMENS)

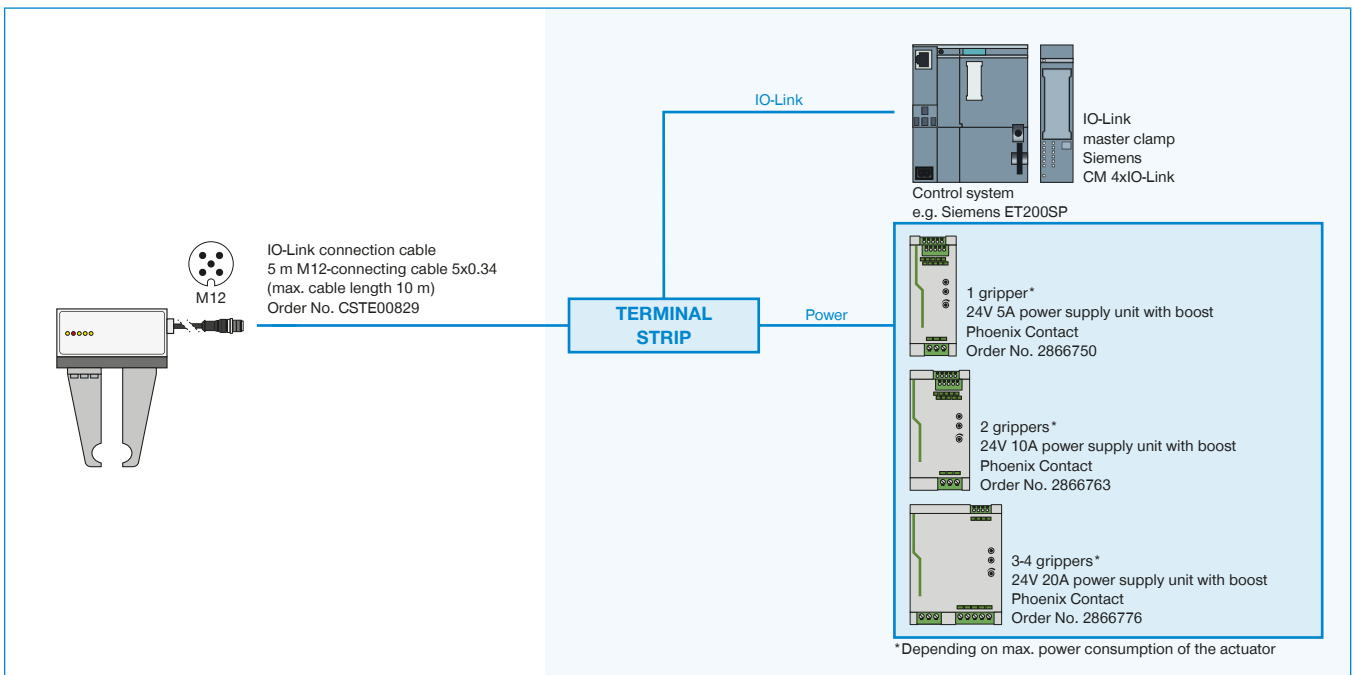

▶ GEH6000IL-03-B WIRING TO IO-LINK MASTER IP67 (BECKHOFF)

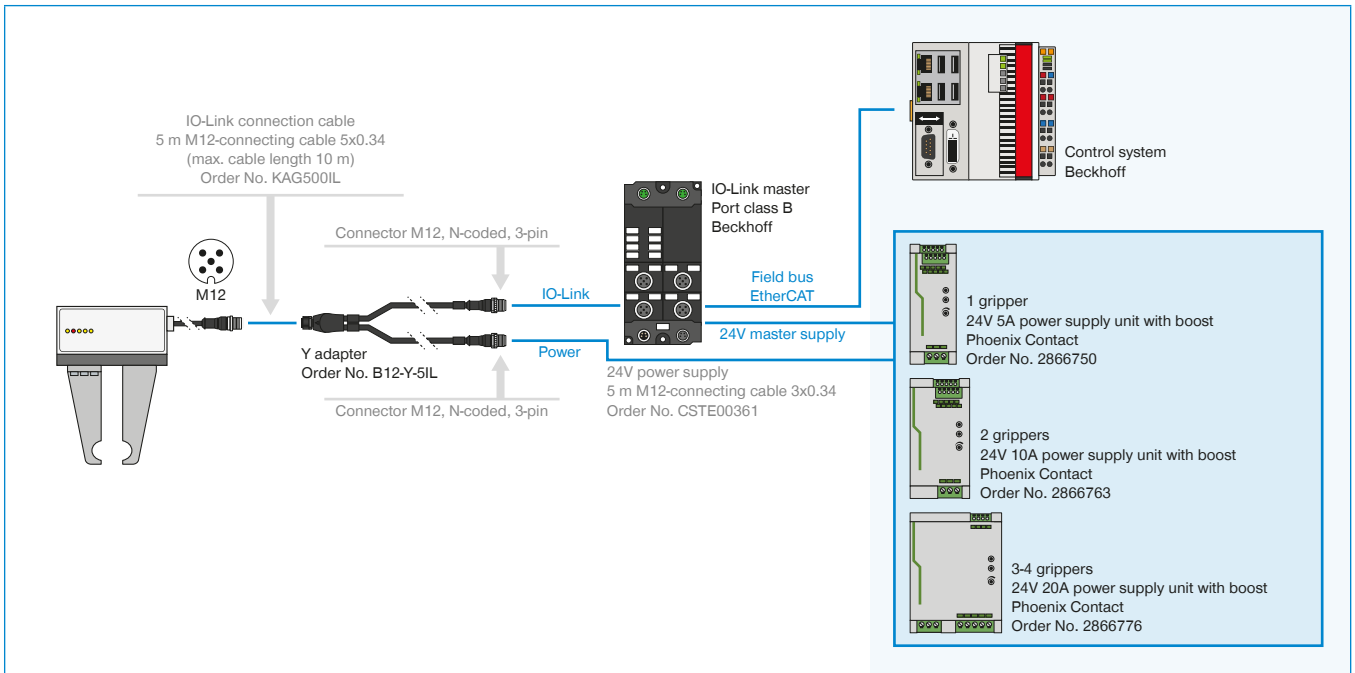

▶ GEH6000IL-31-B WIRING TO IO-LINK MASTER IP67 (BECKHOFF) WITH 1-2 GRIPPERS

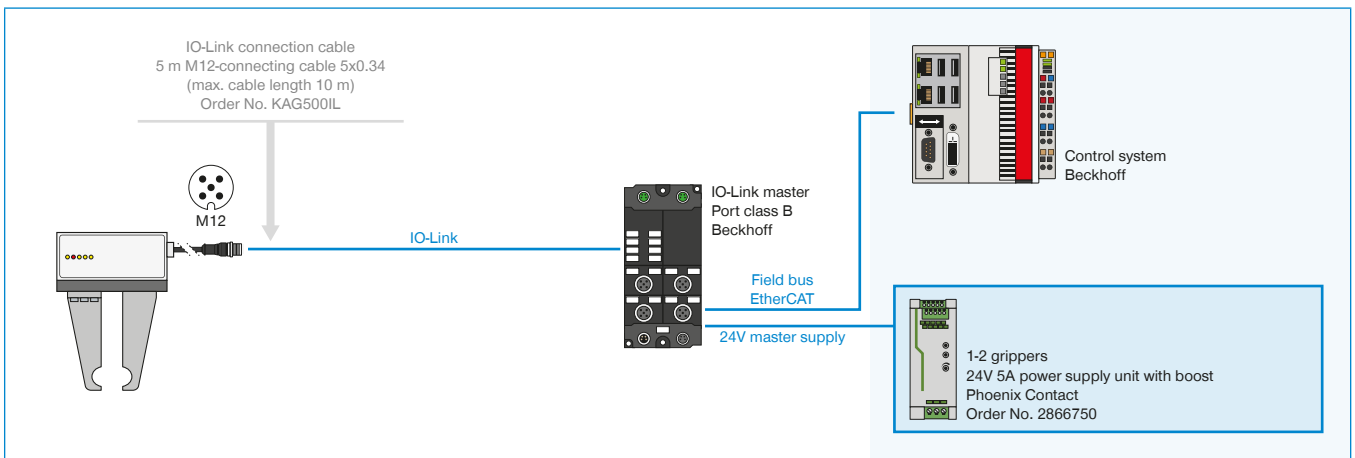

▶ GEH6000IL-31-B WIRING TO IO-LINK MASTER IP67 (BECKHOFF) WITH 3-4 GRIPPERS

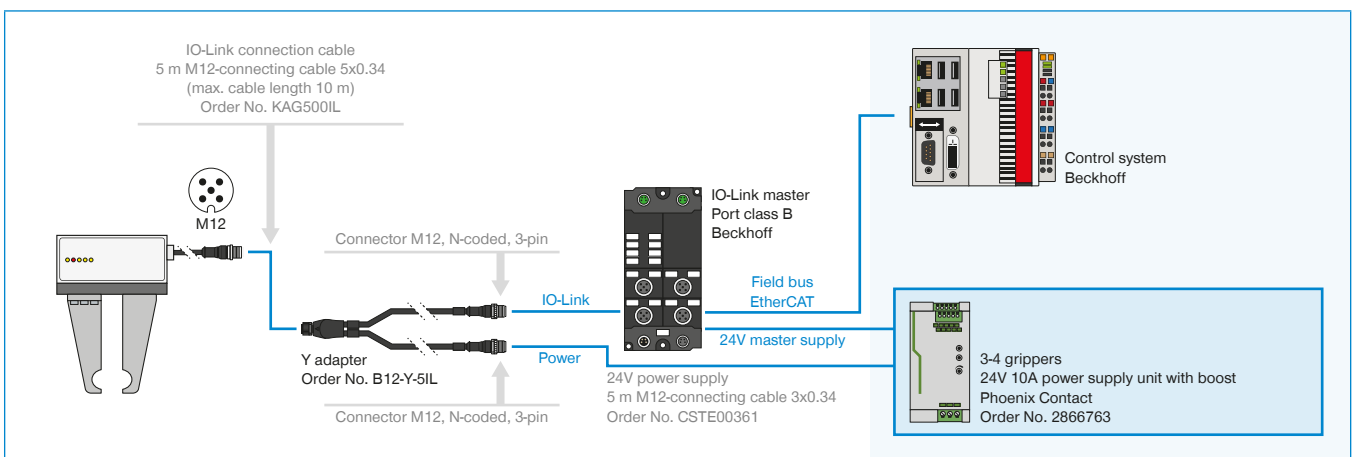

SECURED CONFIGURATION EXAMPLES

GEH6000IL SERIES

▶ GEH6000IL-03-B WIRING TO IO-LINK MASTER IP67 (BECKHOFF)

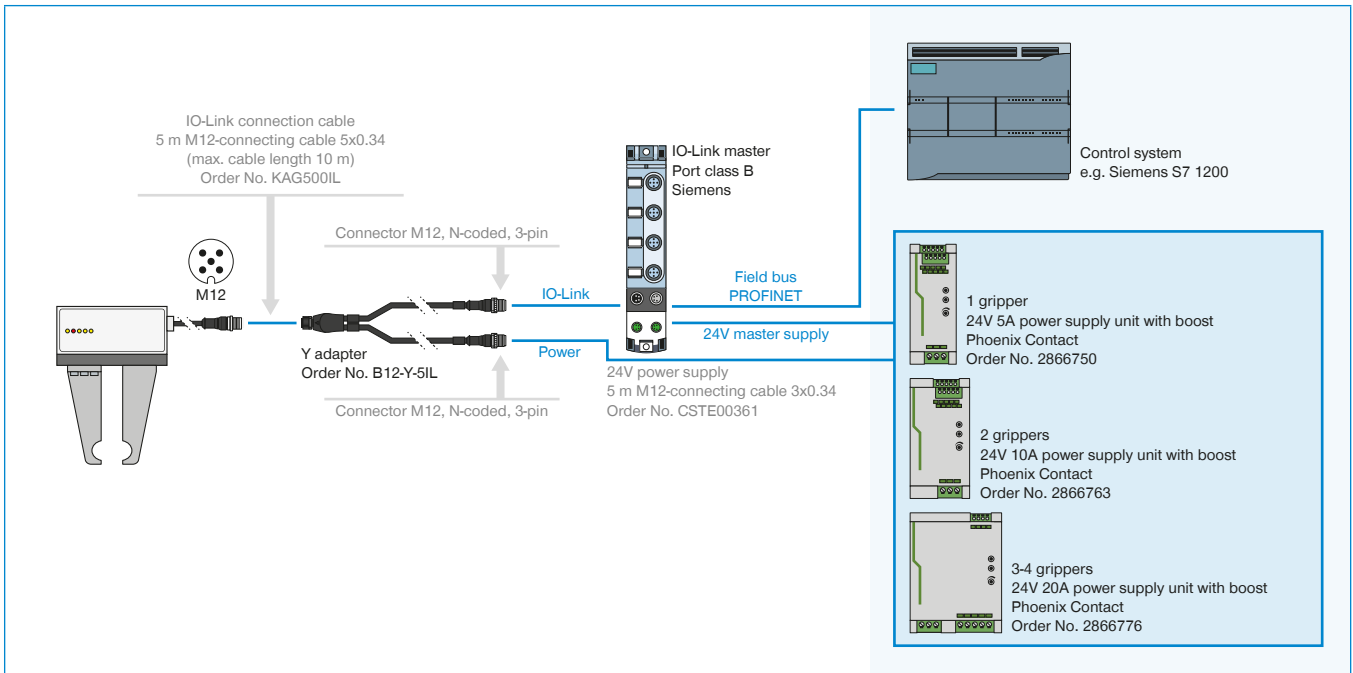

▶ GEH6000IL-31-B WIRING TO IO-LINK MASTER IP67 (SIEMENS) WITH 1-2 GRIPPERS

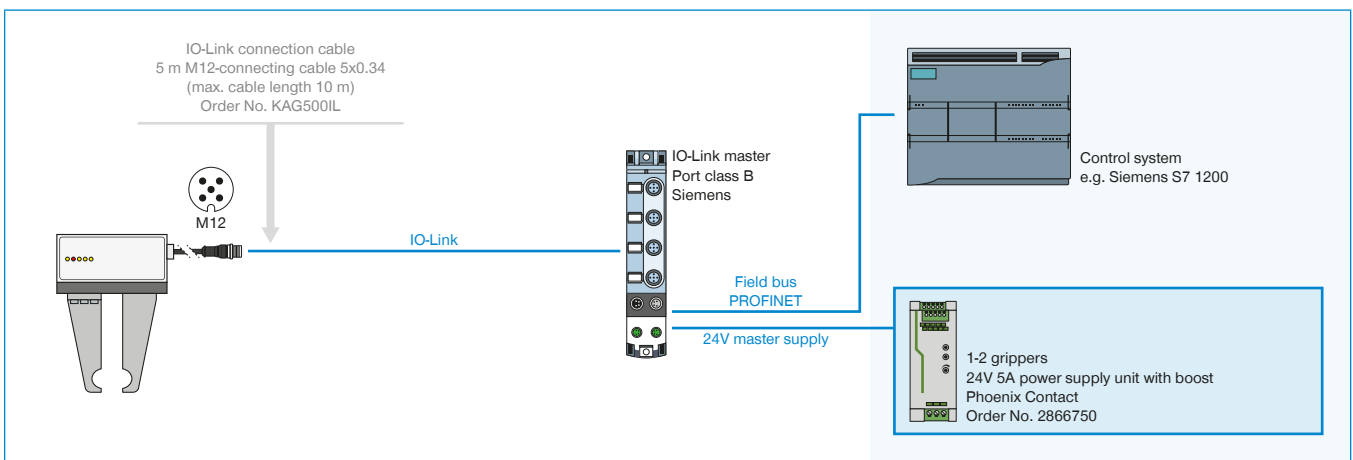

▶ GEH6000IL-31-B WIRING TO IO-LINK MASTER IP67 (SIEMENS) WITH 3-4 GRIPPERS

