

2-JAW PARALLEL GRIPPERS

SERIES GEP2000

▶ PRODUCT ADVANTAGES



🔗 IO-Link

“The electric compact one”

▶ Largest stroke in small installation space

Do you require a large stroke, due to the fact that you are operating either a form fit gripper or a large range of parts but the installation space and the load capacity of your application is limited? Then this gripper is perfect for you!









▶ Adjustable gripping force

Using pressures that are too high can damage your workpieces! You can optimally adjust the gripping force to your workpiece by means of the integrated potentiometer or over the control system via IO-Link.

▶ The simplest activation

It is your choice whether you want to control the gripper by means of I/O ports—like a valve—or if you prefer the version with IO-Link. Both have this in common: they are easy to integrate into your control system.

▶ SERIES CHARACTERISTICS

Installation size	Variants		
	GEP20XX	IL-00	IO-00
 IO-Link	●		
 Digital I/O		●	●
 10 million maintenance-free cycles (max.)	●	●	●
 Magnetic field sensor		●	
 Integrated sensing	●		●
 Gripping force adjustable	●	●	●
 Self locking mechanism	●	●	●
 IP40	●	●	●



► BENEFITS IN DETAIL

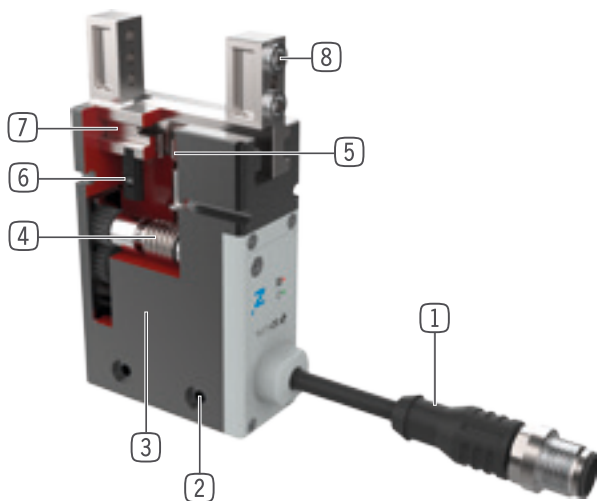

- ① **Control**
 - Via I/O ports (IO) or via IO-Link (IL)
- ② **Mounting and positioning**
 - mounting possible from several sides for versatile positioning
- ③ **BLDC motor**
 - wear-resistant brushless DC motor
- ④ **Helical worm gear**
 - self locking mechanism in case of power drop
- ⑤ **Synchronization**
 - via rack and pinion
- ⑥ **Position sensing**
 - Permanent magnet for direct query of jaw movement via magnetic field sensors
- ⑦ **Gripper jaw**
 - individual gripper finger mounting
- ⑧ **Removable centering sleeves**
 - quick and economical positioning of the gripper fingers

► TECHNICAL DATA

Installation size	Stroke per jaw [mm]	Gripping force [N]	Weight [kg]	IP class
GEP2006	6	40 - 145	0.18	IP40
GEP2010	10	50 - 200	0.31	IP40
GEP2013	13	90 - 360	0.54	IP40
GEP2016	16	125 - 500	0.9	IP40

► FURTHER INFORMATION



Adjustable gripping force

- Four-level gripping force adjustment via rotary switch for digital gripper control
- For the IO-Link variant, gripping force can be conveniently adjusted using the control system



Operating safety

- Mechanical self-locking mechanism, which means that in the event of a power failure, the workpiece is held securely
- Gripper can be mechanically opened by means of an Allen key

2-JAW PARALLEL GRIPPERS

INSTALLATION SIZE GEP2006

▶ PRODUCT SPECIFICATIONS



▶ Gripping force diagram

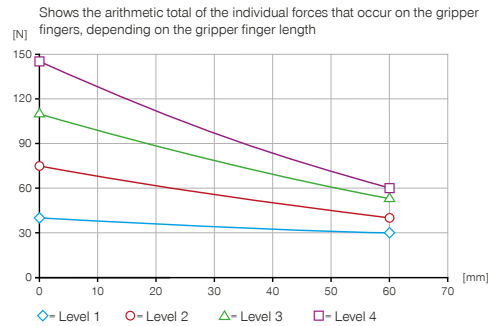

▶ Forces and moments

Displays static forces and moments that can also have an effect, besides the gripping force.



Mr [Nm]	2.5
Mx [Nm]	2.5
My [Nm]	2
Fa [N]	140

▶ TECHNICAL DATA

Order no.	▶ Technical data		
	GEP2006IL-00-A	GEP2006IO-00-A	GEP2006IO-05-A
Control	IO-Link	Digital I/O	Digital I/O
Integrated position sensing	Using process data	No	Analog 0 to 10 V
Stroke per jaw [mm]	6	6	6
Gripping force safety device	mechanical	mechanical	mechanical
Control time [s]	0.03	0.03	0.03
Permissible weight per jaw max [kg]	0.05	0.05	0.05
Length of the gripper fingers max. [mm]	60	60	60
Repetition accuracy +/- [mm]	0.02	0.02	0.02
Operating temperature [°C]	+5 ... +60	+5 ... +60	+5 ... +60
Voltage [V]	24	24	24
Current consumption max. [A]	1	1	1
Minimum positioning path per jaw [mm]	0.5	0.5	0.5
Protection to IEC 60529	IP40	IP40	IP40
Weight [kg]	0.18	0.18	0.18

▶ TECHNICAL DATA OF THE FORCE LEVELS

Order no.	▶ Level 1		
	GEP2006IL-00-A	GEP2006IO-00-A	GEP2006IO-05-A
Gripping force [N]	40	40	40
Closing time / Opening time [s]	0.21 / 0.21	0.21 / 0.21	0.21 / 0.21

Order no.	▶ Level 2		
	GEP2006IL-00-A	GEP2006IO-00-A	GEP2006IO-05-A
Gripping force [N]	75	75	75
Closing time / Opening time [s]	0.15 / 0.15	0.15 / 0.15	0.15 / 0.15

Order no.	▶ Level 3		
	GEP2006IL-00-A	GEP2006IO-00-A	GEP2006IO-05-A
Gripping force [N]	110	110	110
Closing time / Opening time [s]	0.12 / 0.12	0.12 / 0.12	0.12 / 0.12

Order no.	▶ Level 4		
	GEP2006IL-00-A	GEP2006IO-00-A	GEP2006IO-05-A
Gripping force [N]	145	145	145
Closing time / Opening time [s]	0.1 / 0.1	0.1 / 0.1	0.1 / 0.1

▶ TECHNICAL DRAWINGS

- ① Gripper attachment
- ② Energy supply IO-Link (M12, 5-pole)
- ③ Fixing for gripper finger
- ⑥ Integrated slot for magnetic field sensor
- ④④ Energy supply (M8, 4-pole)
- ④⑤ Energy supply (M8, 5-pole)
- ④⑥ Force level setting
- ④⑦ Gripper mounting clamp

GEP2006IL-00-A

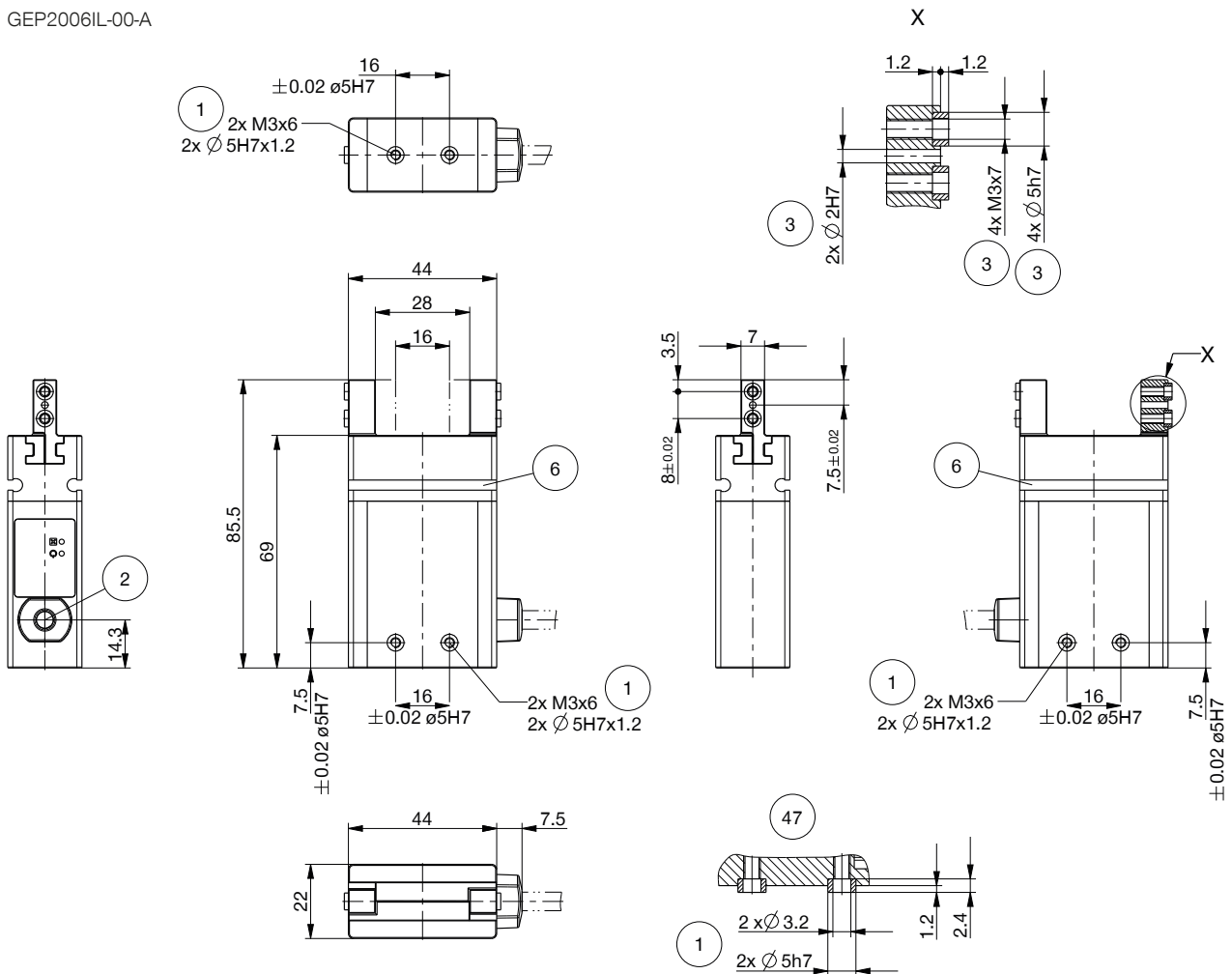

GEP2006IL-00-A

GEP2006IO-00-A

GEP2006IO-05-A

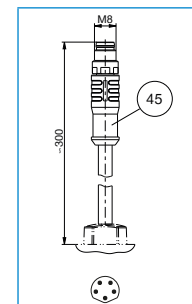
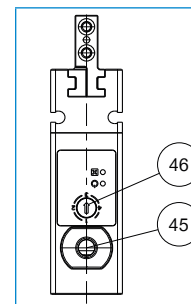
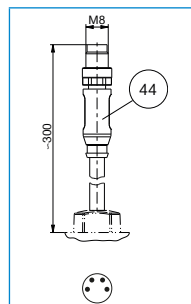
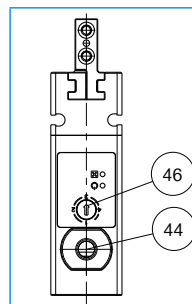
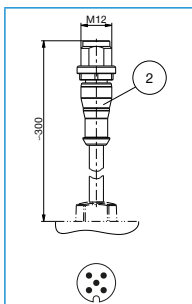
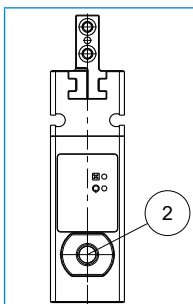

2-JAW PARALLEL GRIPPERS

INSTALLATION SIZE GEP2006

▶ ACCESORIES



▶ INCLUDED IN DELIVERY



6 [piece]
Centering Disc

354237

▶ YOU CAN FIND CONFIGURATION EXAMPLES ON PAGE PL / PL

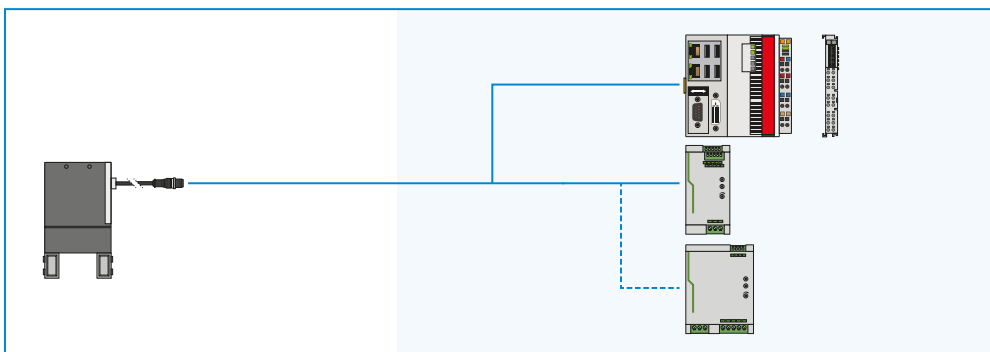

▶ RECOMMENDED ACCESSORY GEP2006IL-00-A



CONNECTIONS / OTHER

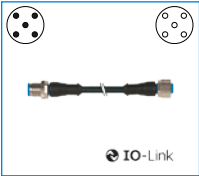

KAG500IL
Plug-in connector straight
5 m - plug, socket M12



AP2006
Adapter plate

▶ RECOMMENDED ACCESSORY GEP2006IO-00-A



SENSORS

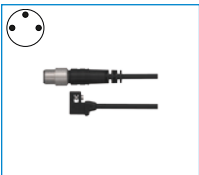

MFS01-S-KHC-P1-PNP
Magnetic field sensor angled,
cable 0.3 m - M8 connector



MFS02-S-KHC-P1-PNP
Magnetic field sensor straight,
cable 0.3 m - M8 connector



MFS01-S-KHC-P2-PNP
2-point sensor angled, ca-
ble 0.3 m - M8 connector



MFS02-S-KHC-P2-PNP
2-point sensor straight, ca-
ble 0.3 m - M8 connector



CONNECTIONS / OTHER

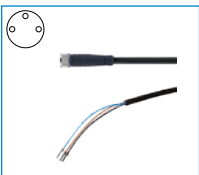

KAG500
Plug-in connector Straight Ca-
ble 5m - Socket M8 (female)

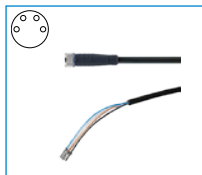

KAG500B4
Plug-in connector Straight Ca-
ble 5m - Socket M8 (female)



S8-G-3
Plug-in connector customiz-
able Straight - Connector M8



S8-G-4
Plug-in connector customiz-
able Straight - Connector M8

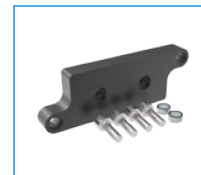

AP2006
Adapter plate

▶ RECOMMENDED ACCESSORY GEP2006IO-05-A



CONNECTIONS / OTHER

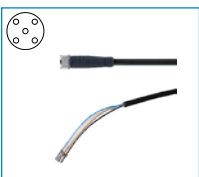

KAG500B5
Plug-in connector Straight Ca-
ble 5m - Socket M8 (female)



AP2006
Adapter plate

2-JAW PARALLEL GRIPPERS

SERIES GEP2000 FUNCTIONAL DESCRIPTION



SENSORS



1-point magnetic field sensors – MFS

For non-contact sensing of the piston position

The sensor is clamped in the C-groove of the gripper and detects the magnet attached to the gripper jaws. The MFS02 is available in versions with 5 m cables with exposed leads and 0,3 m cable with connector.

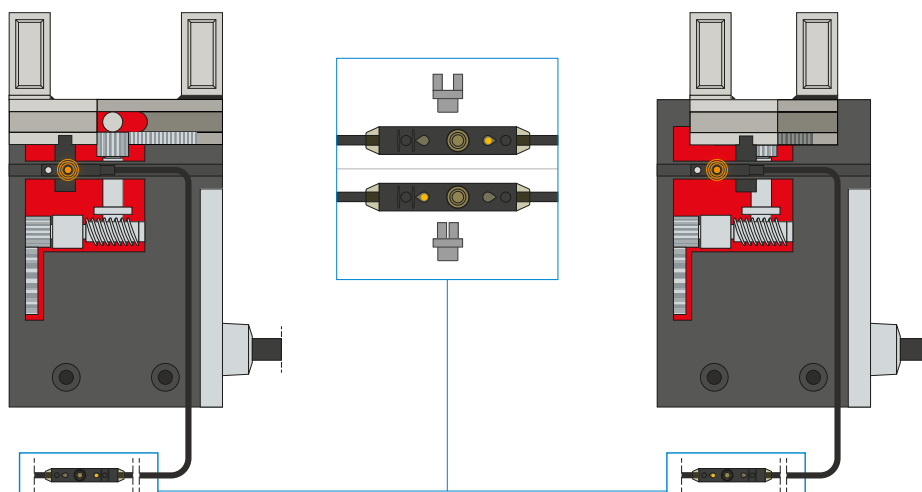

2-point magnetic field sensors – MFS

With two freely programmable switching points

Using the programming unit integrated in the cable, two switch points can be freely defined for this sensor. To do so, the sensor is clamped in the C-groove, the gripper approaches position one and the position is taught in using the teach button. Afterwards, the second position is approached with the gripper and programmed. To ensure use in a wide variety of space conditions, the sensors are available in two variants. While the horizontal MFS02, with straight cable outlet, disappears into the C-groove of the gripper almost completely, the vertical MFS01 is taller, but has a cable outlet that is offset at an angle of 90°. The sensors are available in versions with 5 m cables with exposed leads and 0,3 m cable with connector.



CONNECTIONS / OTHER

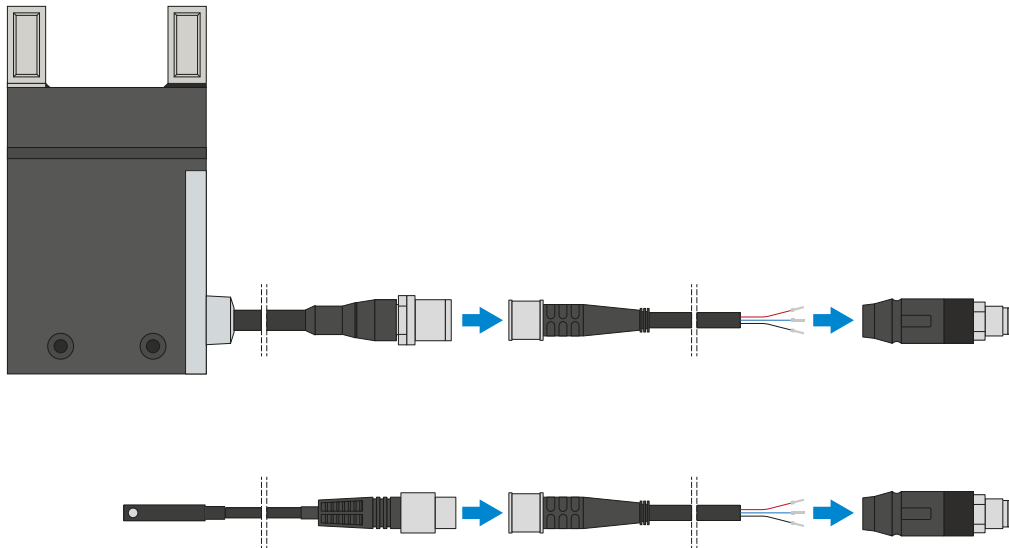

Plug-in connectors

For extending and fabricating the connection lines

Cables with a length of 5 m with exposed leads are available. Depending on the specific needs, the cables can be shortened or fabricated with connectors in sizes M8 and M12. A 5 m long cable with connector / socket is available for the IO-Link connection.

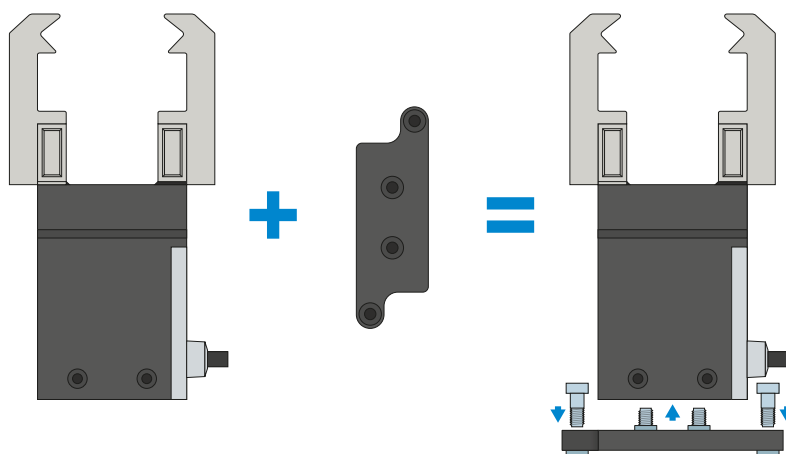

Adapter plate

Additional screw connection option

By attaching the optional adapter plate, the gripper can also be screwed on vertically (from above) if the fastening options integrated into the gripper housing cannot be used for space reasons.

2-JAW PARALLEL GRIPPERS

SERIES GEP2000 FUNCTIONAL DESCRIPTION



CONNECTIONS / OTHER

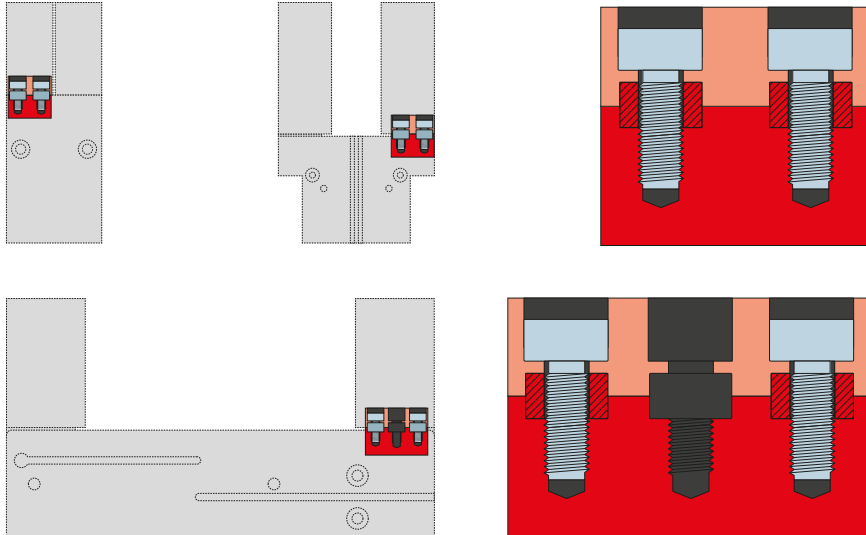

Centering sleeves

For defined position measurement of the gripper fingers

The centering sleeves are inserted into the fits of the gripper jaws to define the position of the gripper fingers. The centering sleeves are comparable to a pin connection.

CONTROL

GEP2000 SERIES

1 IO-LINK CONTROL — GEP2000IL-00-A

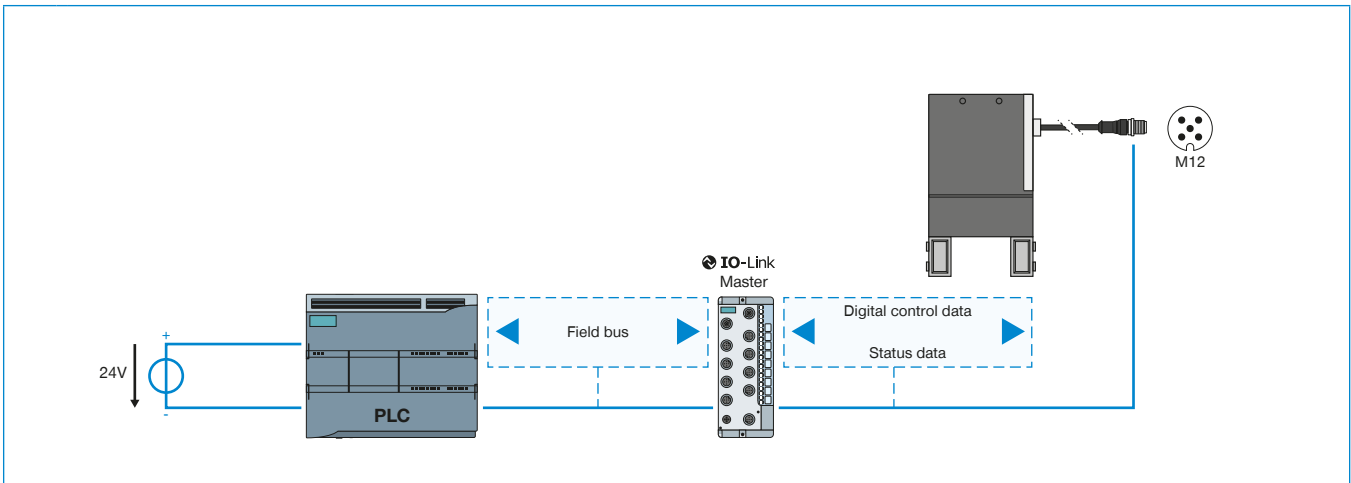

2 DIGITAL CONTROL — GEP2000IO-00-A

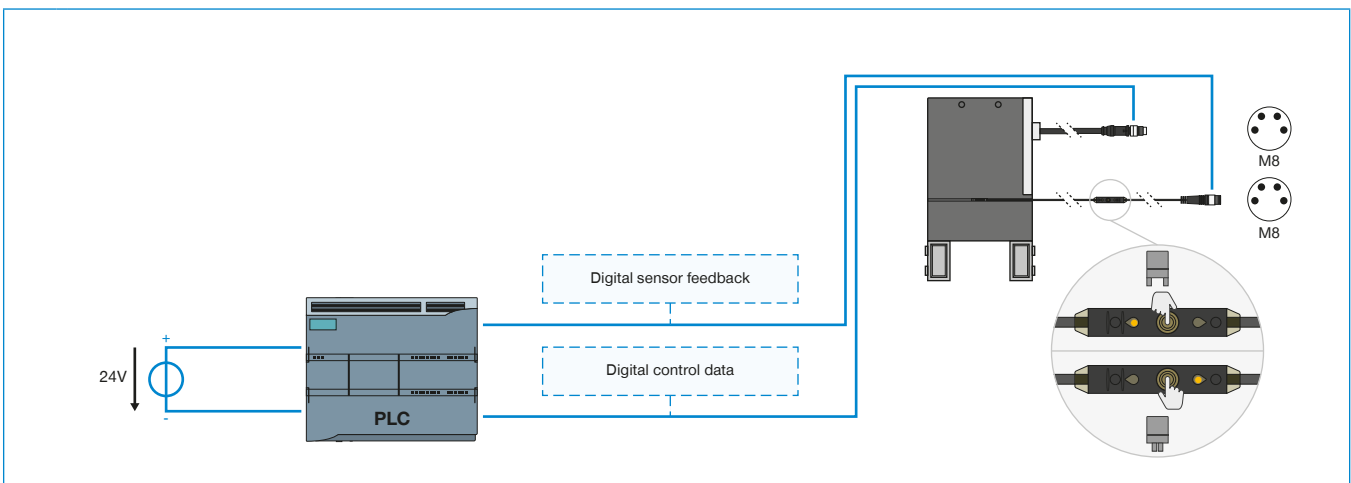

3 DIGITAL CONTROL + INTEGRATED ANALOG SENSING — GEP2000IO-05-A

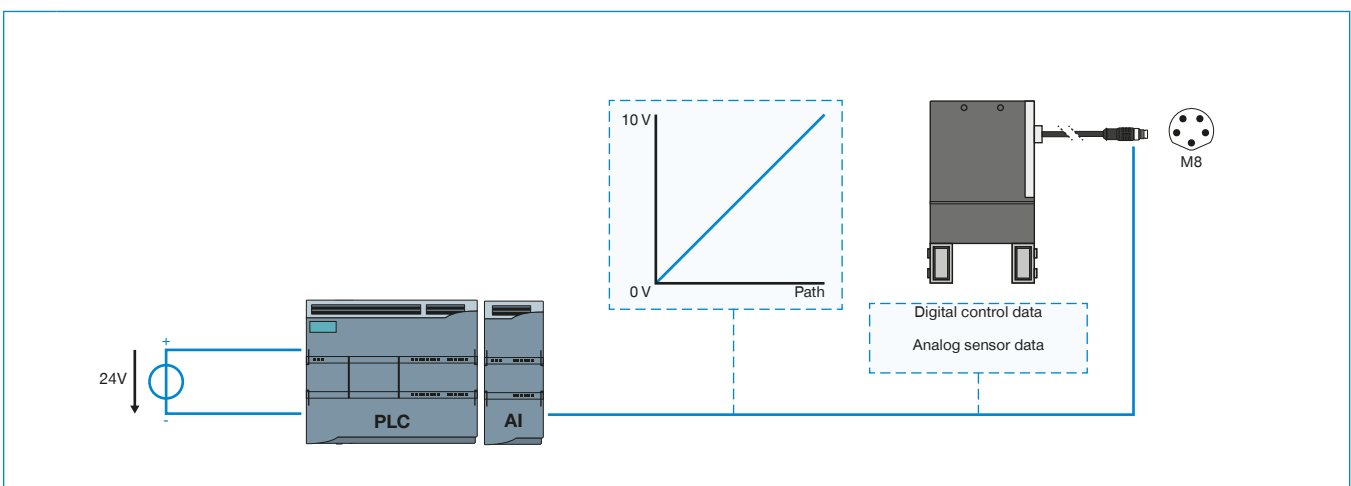

1**▶ IO-LINK CONTROL — GEP2000IL-00-A**

- ▶ Single-cable solution—control system data, status/sensor data and power supply over a single cable
- ▶ Bi-directional data transmission
- ▶ Gripping force and gripping speed can be configured using software
- ▶ 32 workpieces data sets can be programmed
- ▶ Parts detection in range of +/- 0.05 mm with freely teachable area
- ▶ Status data such as temperature and cycle number can be read out
- ▶ Can be integrated into ZIMMER HMI

2**▶ DIGITAL CONTROL — GEP2000IO-00-A**

- ▶ Single-cable solution—control system data and power supply over a single cable
- ▶ Gripper commissioning by means of digital signals
- ▶ Optional digital gripper position feedback via external sensors
- ▶ Gripping force adjustment in four levels to the object being gripped, using rotary switch
- ▶ Can be integrated into ZIMMER HMI

3**▶ DIGITAL CONTROL + INTEGRATED ANALOG SENSING — GEP2000IO-05-A**

- ▶ Single-cable solution—control system data, sensor data and power supply over a single cable
- ▶ Gripper activation by means of digital signals
- ▶ Integrated analog feedback of the gripper position
- ▶ Gripping force adjustment in four levels to the object being gripped, using rotary switch
- ▶ Can be integrated into ZIMMER HMI

SECURED CONFIGURATION EXAMPLES

GEP2000 SERIES

► GEP2000-IL-00-A (IO-LINK) WIRING TO CONTROL CABINET (BECKHOFF)

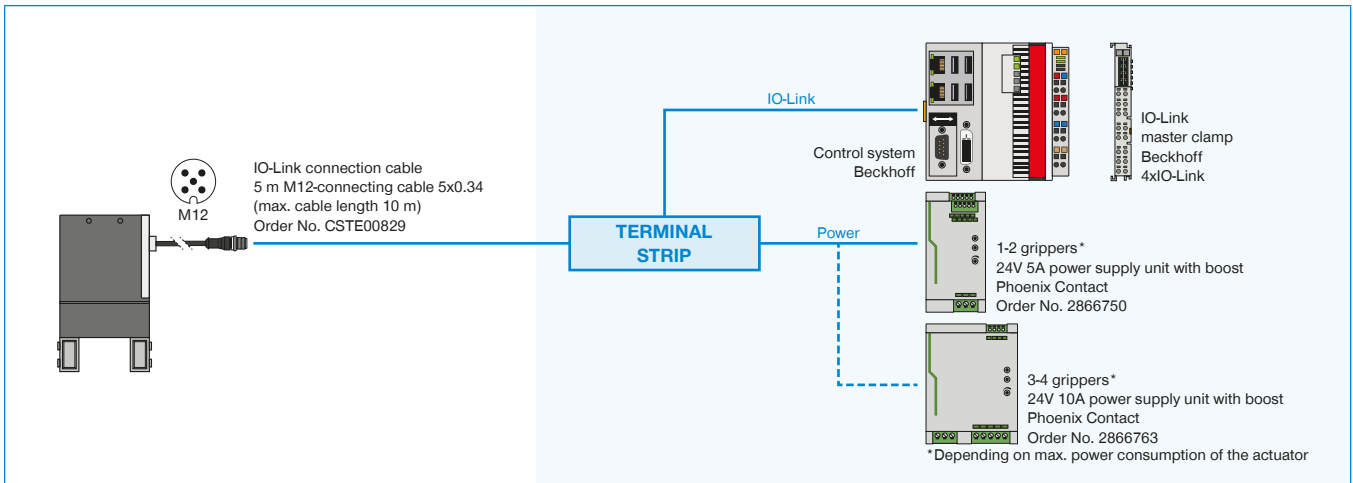

► GEP2000-IL-00-A (IO-LINK) WIRING TO CONTROL CABINET (SIEMENS)

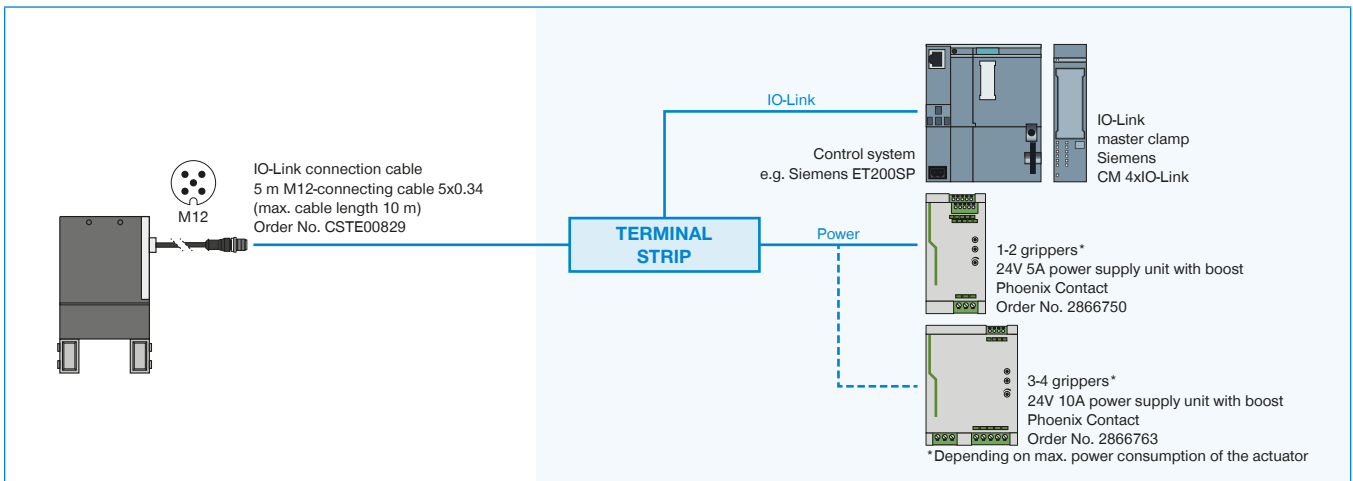

► GEP2000-IL-00-A (IO-LINK) WIRING TO IO-LINK MASTER IP67 (BECKHOFF)

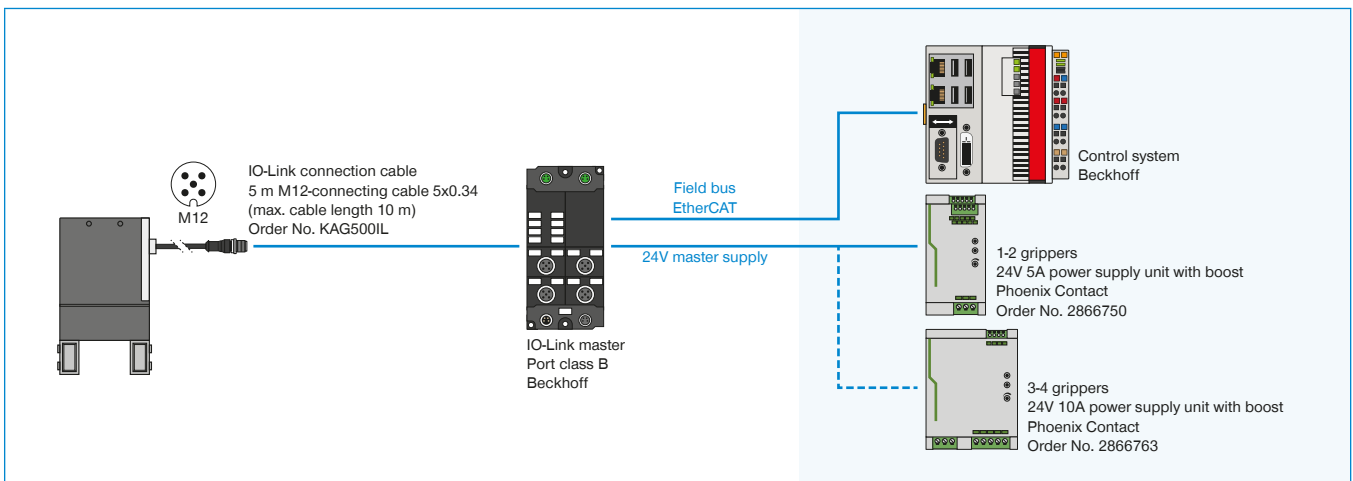

▶ GEP2000-IL-00-A (IO-LINK) WIRING TO IO-LINK MASTER IP67 (SIEMENS)

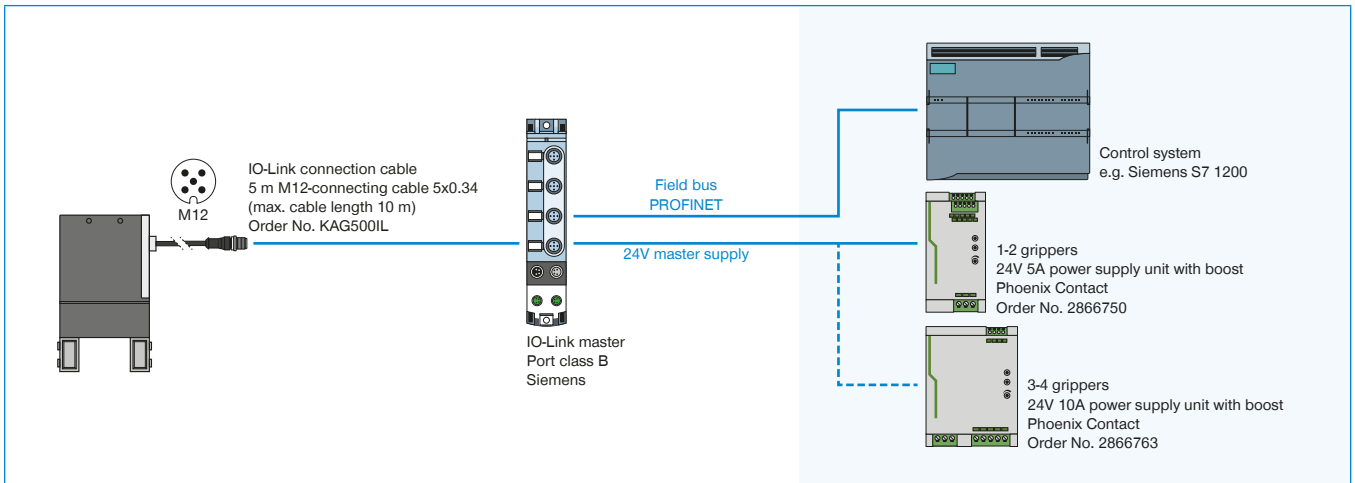

▶ GEP2000-IO-00-A (DIGITAL IO) WIRING TO CONTROL CABINET

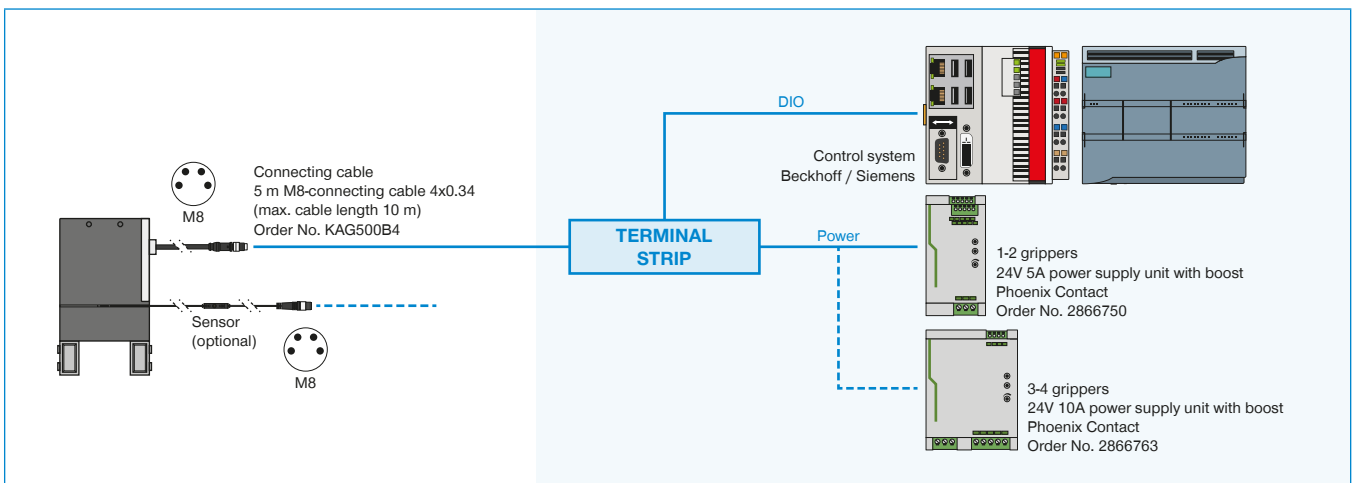

▶ GEP2000-IO-05-A (DIGITAL IO / ANALOG) WIRING TO CONTROL CABINET

