

# 2-JAW PARALLEL GRIPPERS

## SERIES GP

### ▶ PRODUCT ADVANTAGES

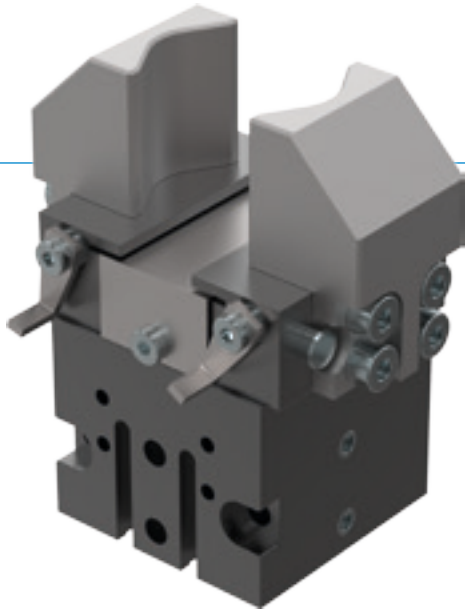

#### “The enduring”

##### ▶ Proven technology

We have more than 20 years of proven reliability, which ensures uninterrupted production for you







##### ▶ Very short cycle times

Low-friction circular guides enable very short cycle times and, therefore, high component output for your machine

##### ▶ Failure-free continuous operation

Our uncompromising “Made in Germany” quality guarantees up to 10 million maintenance-free cycles

### ▶ SERIES CHARACTERISTICS

Installation size	Version	
GPXXX	-C	S-C
 Spring closing C		•
 High-strength S		•
 10 million maintenance-free cycles (max.)	•	•
 Inductive sensor	•	•
 Magnetic field sensor	•	•
 IP30	•	•



## ► BENEFITS IN DETAIL

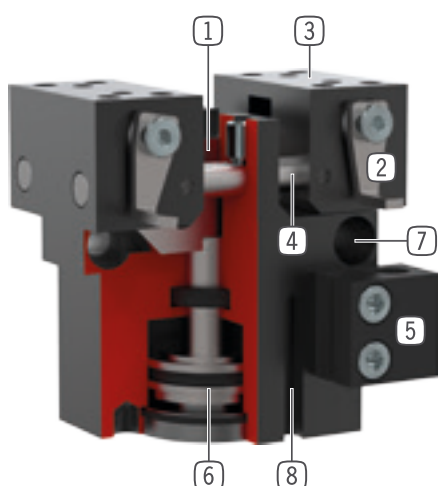

- ① **Wedge hook mechanism**
  - synchronized the movement of the gripper jaws
  - high force transfer
- ② **Adjustable switch cam**
  - for position sensing
- ③ **Gripper jaw**
  - individual gripper finger mounting
- ④ **Roller slide**
  - for low wear movement sequence
- ⑤ **Mounting block**
  - mounting for inductive proximity switch
- ⑥ **Drive**
  - double-acting pneumatic cylinder
- ⑦ **Mounting and positioning**
  - mounting possible from several sides for versatile positioning
- ⑧ **Sensing slot**
  - mounting and positioning of magnetic field sensors

## ► TECHNICAL DATA

Installation size	Stroke per jaw [mm]	Gripping force [N]	Weight [kg]	IP class
GP12	3	8,4	0.034	IP30
GP19	4	36	0.085	IP30
GP30	5	94	0.155	IP30
GP45	5	118 - 190	0.236 - 0.271	IP30
GP75	10	220 - 275	0.466 - 0.511	IP30
GP100	8 - 13	450 - 5250	1.295 - 1.311	IP30

## ► FURTHER INFORMATION IS AVAILABLE ONLINE



All information just a click away at: [www.zimmer-group.com](http://www.zimmer-group.com). Find data, illustrations, 3D models and operating instructions for your installation size using the order number for your desired product. Quick, clear and always up-to-date.

# 2-JAW PARALLEL GRIPPERS

## INSTALLATION SIZE GP30

### ▶ PRODUCT SPECIFICATIONS

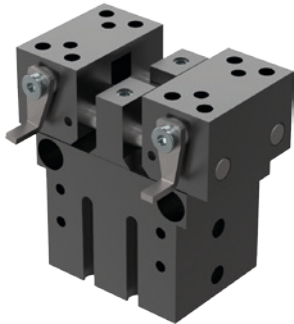

#### ▶ Gripping force diagram

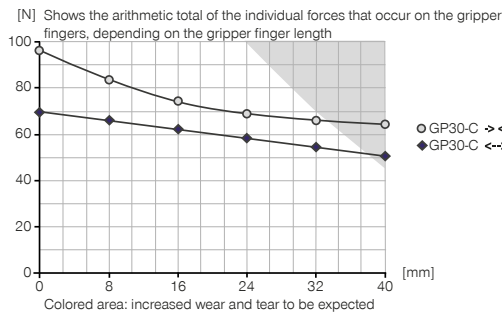

#### ▶ Forces and moments

Displays static forces and moments that can also have an effect, besides the gripping force.

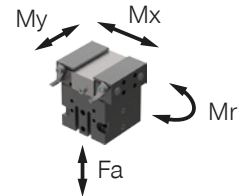

Mr [Nm]	2
Mx [Nm]	2
My [Nm]	2
Fa [N]	80

### ▶ RECOMMENDED ACCESSORIES



#### GRIPPING COMPONENTS



**UB30**  
Universal jaw set aluminium



#### SENSORS



**NJ5-E2**  
Inductive proximity switch - Cable 5 m



#### ENERGY SUPPLY



**GVM5**  
Straight Fittings - Quick Connect Style



**NJ5-E2SK**  
Inductive Proximity Switch Cable 0,3 m - Connector M8



**WVM5**  
Angled Fittings - Quick Connect Style



**MFS01-S-KHC-P1-PNP**  
Magnetic field sensor angled, cable 0.3 m - M8 connector



**DEV04**  
Quick Exhaust Valve



**MFS02-S-KHC-P1-PNP**  
Magnetic field sensor straight, cable 0.3 m - M8 connector



**DSV1-8**  
Pressure safety valve



**MFS01-S-KHC-P2-PNP**  
2-point sensor angled, cable 0.3 m - M8 connector



**DSV1-8E**  
Pressure safety valve with quick exhaust



**MFS02-S-KHC-P2-PNP**  
2-point sensor straight, cable 0.3 m - M8 connector



#### CONNECTIONS / OTHER



#### SENSORS



**KB5**  
Mounting block



**KAG500**  
Plug-in connector Straight Cable 5m - Socket M8 (female)



**ZE15H7X4**  
Centering Disc

Order no.	GP30-C
Stroke per jaw [mm]	5
Gripping force in closing [N]	94
Gripping force in opening [N]	76
Gripping force secured by spring min. [N]	
Closing time [s]	0.02
Opening time [s]	0.02
Repetition accuracy +/- [mm]	0.05
Operating pressure min. [bar]	3
Operating pressure max. [bar]	8
Nominal operating pressure [bar]	6
Operating temperature min. [°C]	+5
Operating temperature max. [°C]	+80
Air volume per cycle [cm <sup>3</sup> ]	3.0
Weight [kg]	0.15

► Technical data

