

# 3-JAW CONCENTRIC GRIPPERS

## SERIES GPD5000

### ▶ PRODUCT ADVANTAGES

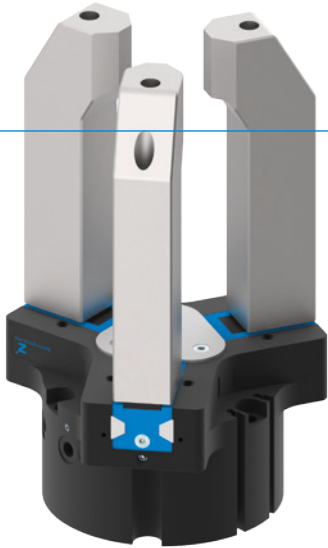

#### “The best”

##### ▶ **Steel Linear Guide – The superior guidance system concept**

The steel / steel guide stands for lasting precision, durability and a long service life—featuring maintenance intervals of up to 30 million gripping cycles. Benefit from these features and increase the profitability and process reliability of your machine.

##### ▶ **Leakproof and corrosion protected – The universal gripper**

Suitable for virtually all ambient conditions, with a sealed guide up to IP67 and corrosion protection as standard, you are able to use this gripper universally. As a result, the range of models in your production is reduced, along with a reduction in associated storage and process costs.

##### ▶ **Aluminum Linear Guide – The alternative**

Reduced to those aspects which are the most important, the steel / aluminum guide variant offers significantly better performance when compared to a similar gripper with a T-groove travel guide, and is on par with the best principles of toothed guidance systems.

### ▶ BENEFITS IN DETAIL

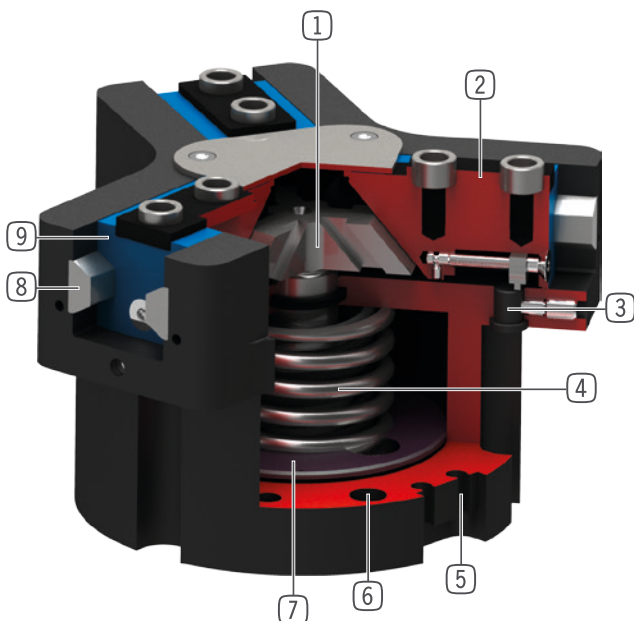

#### ① **Wedge hook mechanism**

- high forces and moments capacity
- Synchronized gripper jaw movement

#### ② **Gripper jaw**

- Gripper fingers mounted using removable centering sleeves
- Lubricated for life via incorporated lubrication slots

#### ③ **Mounting block**

- mounting for inductive proximity switch

#### ④ **Integrated gripping force safety device**

- Spring built into cylinder chamber as an energy store

#### ⑤ **Sensing slot**

- mounting and positioning of magnetic field sensors

#### ⑥ **Mounting and positioning**

- Alternatively, on several sides for customized mounting
- Pneumatic and electrical versions identical apart from height

#### ⑦ **Drive**

- Double-acting pneumatic rotor cylinder

#### ⑧ **Steel Linear Guide**

- Steel in steel guide
- Enables use of extremely long gripper fingers
- Also available in steel / aluminum variant

#### ⑨ **Dual lip seal**

- IP64 and up to IP67 (with purged air) for Protector version
- Prevents grease from being squeezed out, increasing service life



## ► SERIES CHARACTERISTICS

Installation size		Variants				
GPD50XX		-00	-20	-21	-24	-AL
N	Long stroke	•	•	•	•	•
NC	Long stroke / Spring closing	•	•	•	•	•
NO	Long stroke / Spring opening	•	•	•	•	•
S	High-strength	•	•	•	•	
SC	High-strength / Spring closing	•	•	•	•	
SO	High-strength / Spring opening	•	•	•	•	
	Steel / steel guide	•	•	•	•	
	Steel / aluminum guide					•
	15 million maintenance-free cycles (max.)					•
	30 million maintenance-free cycles (max.)	•	•	•	•	
	Inductive sensor	•	•	•	•	
	Magnetic field sensor	•	•	•	•	•
	Protected against corrosion	•	•	•	•	
	Purged air	•	•	•	•	•
	Temperature-resistant		•		•	
	IP40					•
	IP64	•	•			
	IP67*			•	•	

\*with purged air (max. 0,5 bar)

## ► TECHNICAL DATA

Installation size	Stroke per jaw [mm]	Gripping force [N]	Weight [kg]	IP class
GPD5003	2,5	310 - 465	0,14 - 0,22	IP40 / IP64 / IP67 *
GPD5004	2 - 4	460 - 1520	0,27 - 0,41	IP40 / IP64 / IP67 *
GPD5006	3 - 6	740 - 2370	0,48 - 0,58	IP40 / IP64 / IP67 *
GPD5008	4 - 8	1260 - 3910	0,83 - 1	IP40 / IP64 / IP67 *
GPD5010	5 - 10	2290 - 7160	1,45 - 1,9	IP40 / IP64 / IP67 *
GPD5013	6 - 13	3770 - 11450	2,6 - 3,7	IP64 / IP67 *
GPD5016	8 - 16	6870 - 20330	5,7 - 7,5	IP64 / IP67 *
GPD5025	14 - 25	8430 - 22850	11,8 - 15,4	IP64 / IP67 *
GPD5030	17 - 30	12130 - 32400	21 - 27,5	IP64 / IP67 *
GPD5035	20 - 35	16600 - 45200	37,8 - 42	IP64 / IP67 *
GPD5045	26 - 45	27900 - 72500	78,6 - 99,9	IP64 / IP67 *

\*with purged air (max. 0,5 bar)

# 3-JAW CONCENTRIC GRIPPERS

## INSTALLATION SIZE GPD5025

### ▶ PRODUCT SPECIFICATIONS

-00-A / -20-A / -21-A / -24-A

Steel / steel guide

#### ▶ Gripping force diagram

Shows the arithmetic total of the individual forces that occur on the gripper fingers, depending on the gripper finger length

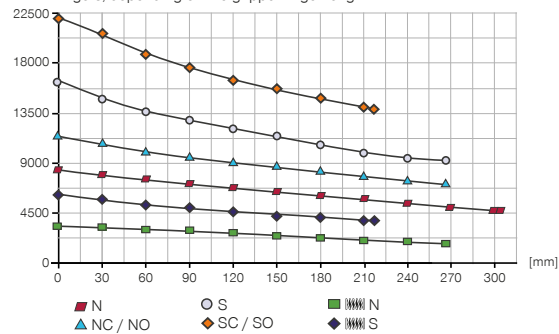

#### ▶ Forces and moments

Displays static forces and moments that can also have an effect, besides the gripping force.

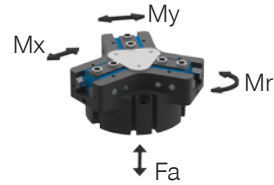

Mr [Nm]	180
Mx [Nm]	205
My [Nm]	225
Fa [N]	7500

### ▶ VARIANTS

-00-A / -20-A

Steel / steel guide

-21-A / -24-A

Steel / steel guide



## ▶ TECHNICAL DATA

	▶ Technical data					
Order no.	GPD5025N-00-A	GPD5025NC-00-A	GPD5025NO-00-A	GPD5025S-00-A	GPD5025SC-00-A	GPD5025SO-00-A
Stroke per jaw [mm]	25	25	25	14	14	14
Gripping force in closing [N]	8430	11560		16240	22270	
Gripping force in opening [N]	8730		11860	16820		22850
Gripping force secured by spring min. [N]		3130	3130		6030	6030
Closing time [s]	0.6	0.6	1.0	0.6	0.6	1.0
Opening time [s]	0.6	1.0	0.6	0.6	1.0	0.6
Permissible weight per jaw max [kg]	7	7	7	7	7	7
Length of the gripper fingers max. [mm]	310	265	265	265	220	220
Repetition accuracy +/- [mm]	0.05	0.05	0.05	0.05	0.05	0.05
Operating pressure min. [bar]	3	4	4	3	4	4
Operating pressure max. [bar]	8	7	7	8	7	7
Nominal operating pressure [bar]	6	6	6	6	6	6
Operating temperature [°C]	-10 ... +90	-10 ... +90	-10 ... +90	-10 ... +90	-10 ... +90	-10 ... +90
Air volume per cycle [cm <sup>3</sup> ]	1025	1750	1750	1025	1750	1750
Protection to IEC 60529	IP64	IP64	IP64	IP64	IP64	IP64
Weight [kg]	11.8	15.4	15.4	11.8	15.4	15.4

	▶ Technical Data - High Temperature Version					
Order no.	GPD5025N-20-A	GPD5025NC-20-A	GPD5025NO-20-A	GPD5025S-20-A	GPD5025SC-20-A	GPD5025SO-20-A
Operating temperature [°C]	-10 ... +130	-10 ... +130	-10 ... +130	-10 ... +130	-10 ... +130	-10 ... +130

	▶ Technical Data - Protector Version					
Order no.	GPD5025N-21-A	GPD5025NC-21-A	GPD5025NO-21-A	GPD5025S-21-A	GPD5025SC-21-A	GPD5025SO-21-A
Protection to IEC 60529	IP67*	IP67*	IP67*	IP67*	IP67*	IP67*
Weight [kg]	14	17.6	17.6	14	17.6	17.6

	▶ Technical Data - High Temperature Protector Version					
Order no.	GPD5025N-24-A	GPD5025NC-24-A	GPD5025NO-24-A	GPD5025S-24-A	GPD5025SC-24-A	GPD5025SO-24-A
Operating temperature [°C]	-10 ... +130	-10 ... +130	-10 ... +130	-10 ... +130	-10 ... +130	-10 ... +130
Protection to IEC 60529	IP67*	IP67*	IP67*	IP67*	IP67*	IP67*
Weight [kg]	14	17.6	17.6	14	17.6	17.6

\*with purged air (max. 0,5 bar)

# 3-JAW CONCENTRIC GRIPPERS

## INSTALLATION SIZE GPD5025

### TECHNICAL DRAWINGS

NC / NO / SC / SO  
-00-A / -20-A

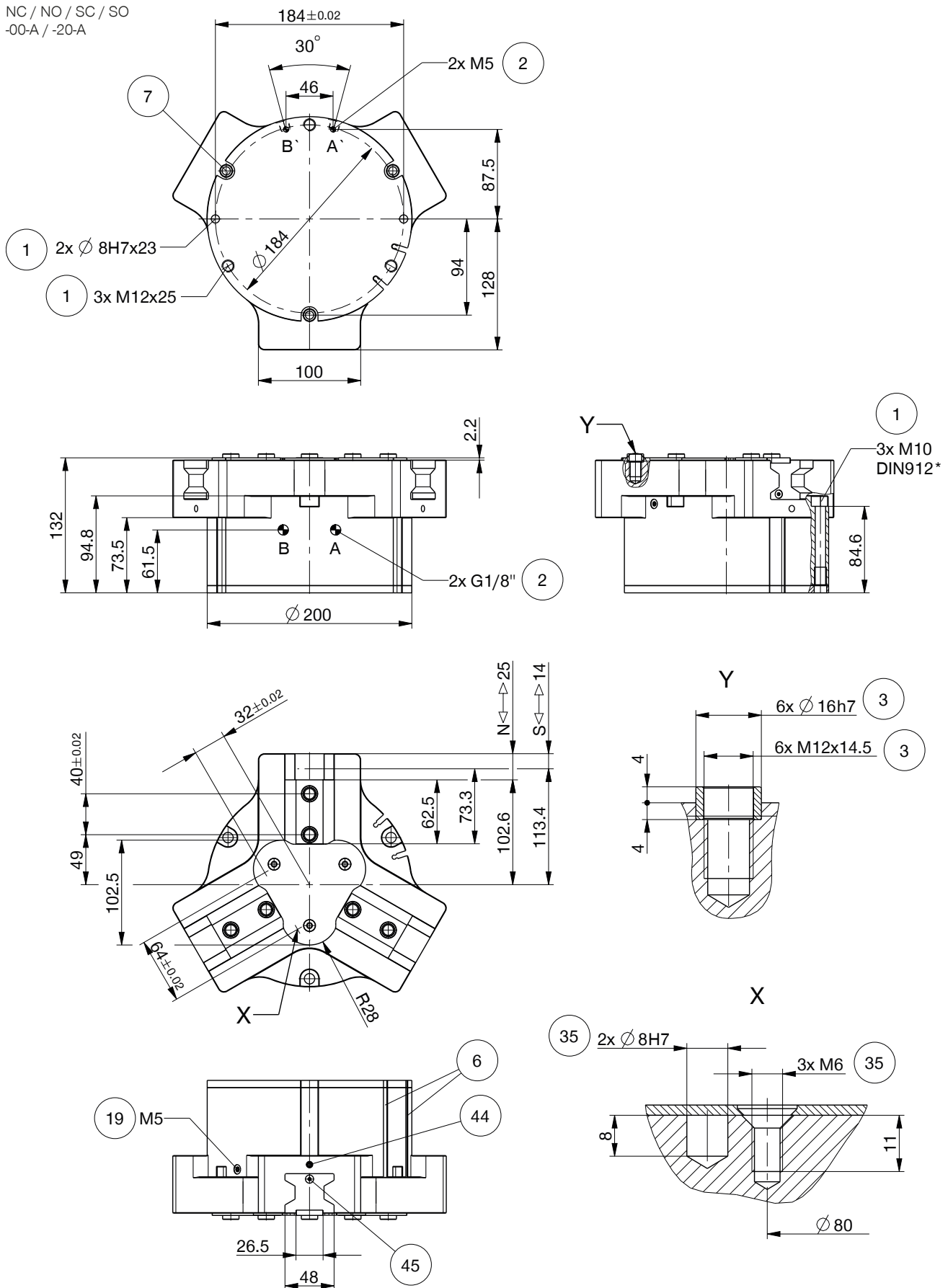

## ▶ TECHNICAL DRAWINGS

N / S  
-00-A / -20-A

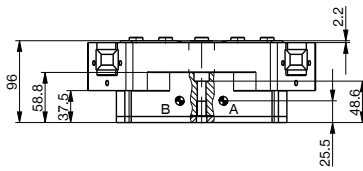

N / NC / NO / S / SC / SO  
-21-A / -24-A

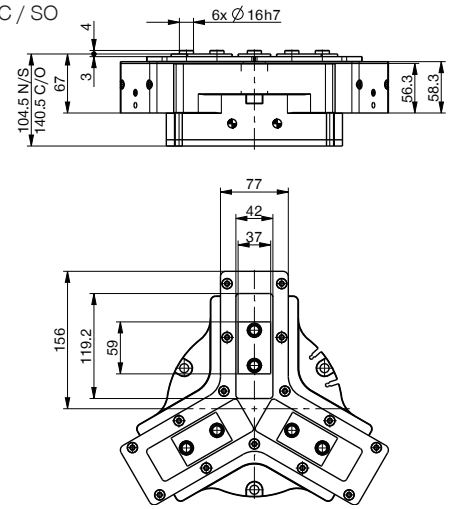

Hoseless air feed-through M5

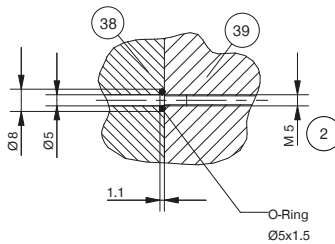

- |   |                                       |
|---|---------------------------------------|
| ① Gripper attachment                                | ③⑨ Gripper                            |
| ② Energy supply                                     | ④④ Clamp for sensor                   |
| ③ Fixing for gripper finger                         | ④⑤ Switch cam adjustment              |
| ⑥ Integrated slot for magnetic field sensor         | Ⓐ Air connection (close)              |
| ⑦ Mounting block                                    | Ⓑ Air connection (open)               |
| ①⑨ Air purge connection option (max. 0,5 bar)       | Ⓐ Air connection, alternative (close) |
| ③⑤ Attachment option for customer-specific fittings | Ⓑ Air connection, alternative (open)  |
| ③⑧ Adapter  |                                       |



# 3-JAW CONCENTRIC GRIPPERS

## INSTALLATION SIZE GPD5025

### ▶ ACCESORIES

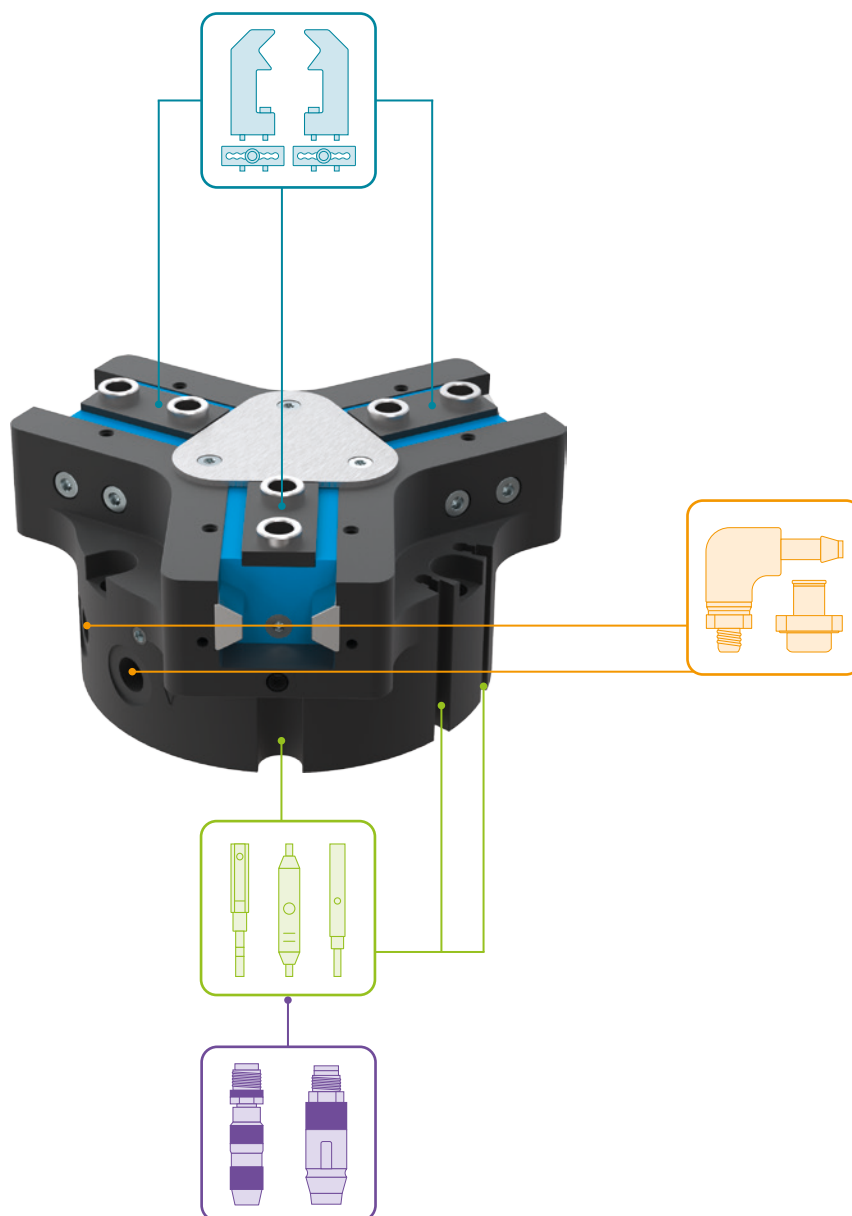

### ▶ INCLUDED IN DELIVERY



6 [piece]  
Centering Disc

030529

## ▶ RECOMMENDED ACCESSORIES



### GRIPPING COMPONENTS

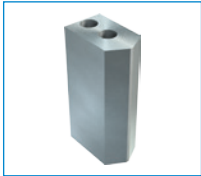

**UB5025AL**  
Universal jaw aluminium



**UB5025ST**  
Universal jaw steel



**EB5025AL**  
Aluminum adjustment jaw



**EB5025ST**  
Steel adjustment jaw

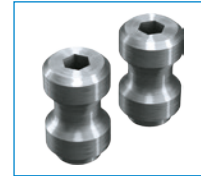

**WB5025L**  
Changeable jaw, loose-part-set

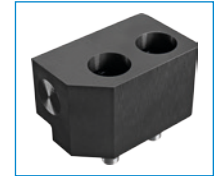

**WB5025F**  
Changeable jaw, fix-part



**ADS5025-01**  
Pressure piece N / S



**ADS5025-02**  
Pressure piece NC / NO / SC / SO



### ENERGY SUPPLY



**WV1-8X8**  
Angled Fittings - Quick Connect Style



**DSV1-8**  
Pressure safety valve

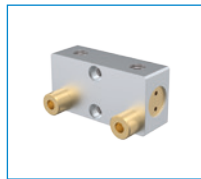

**DSV1-8E**  
Pressure safety valve with quick exhaust



### SENSORS



**NJ8-E2S**  
Inductive proximity switch - Connector M8



**MFS01-S-KHC-P1-PNP**  
Magnetic field sensor angled, cable 0.3 m - M8 connector



**MFS02-S-KHC-P1-PNP**  
Magnetic field sensor straight, cable 0.3 m - M8 connector



**MFS01-S-KHC-P2-PNP**  
2-point sensor angled, cable 0.3 m - M8 connector

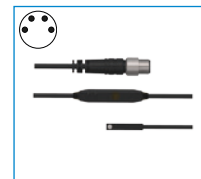

**MFS02-S-KHC-P2-PNP**  
2-point sensor straight, cable 0.3 m - M8 connector



### CONNECTIONS / OTHER

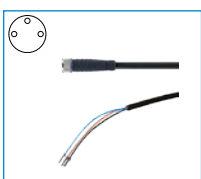

**KAG500**  
Plug-in connector Straight Cable 5m - Socket M8 (female)



# 3-JAW CONCENTRIC GRIPPERS

## SERIES GPD5000 FUNCTIONAL DESCRIPTION



### GRIPPING COMPONENTS

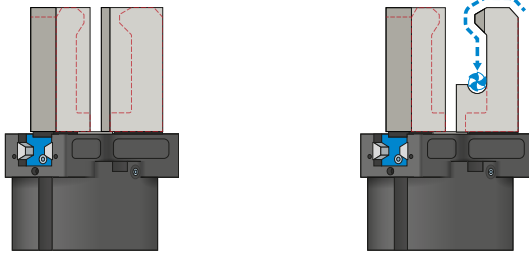

#### Universal jaws – UB5000

Can be used immediately or for individual reprocessing

The gripper blanks are available in aluminum (AL) and steel (ST) versions and are installed directly on the gripper using the screws in the scope of delivery. The fits for the centering sleeves are already in place for this purpose. One universal jaw is required for each gripper jaw.

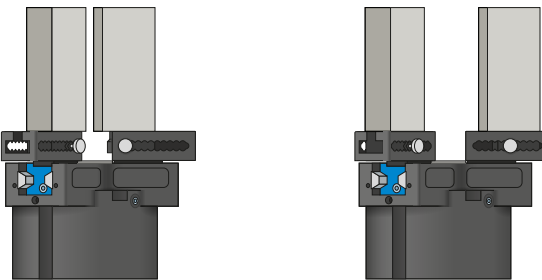

#### Adjustment jaws – EB5000

For tool-free adaptation of the gripper range

By manually activating the locking mechanism, which is pre-tensioned by a spring, the adjustment jaw can be moved within a grid of detent notches that has a number scale. Depending on the forces and torques that apply, the adjustment jaws are available in aluminum (AL) and steel (ST) versions. One adjustment jaw is required for each gripper jaw.

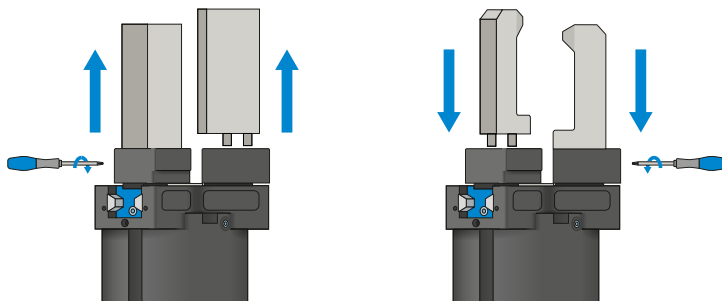

#### Interchangeable jaws – WB5000

Enable fast change of individual gripper fingers

For each gripper jaw, a fixed part and at least one loose part set is needed, depending on the number of gripper fingers to be changed. Manual locking via the Torx wrench included in the scope of delivery of the fixed part can take place from two sides.



### THE GRIPPING COMPONENTS CAN BE COMBINED!

The gripper components listed above can be combined with each other and are compatible with the various series of the 5000 gripper family.



## GRIPPING COMPONENTS

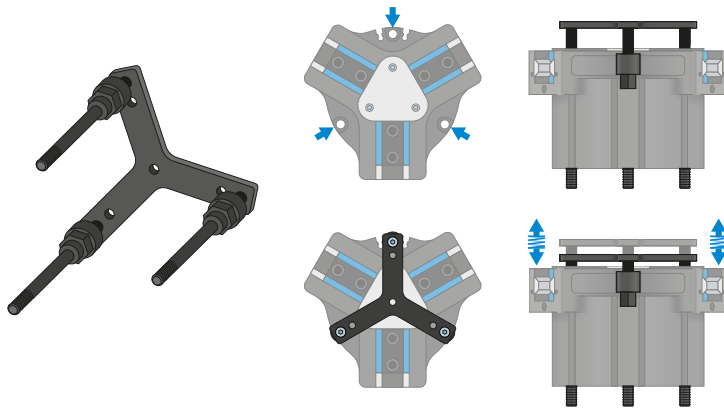

### Pressure piece – ADS5000

When the gripper fingers are open, the pressure piece is used for spring-supported positioning of the workpiece against a limit stop. This greatly reduces the loads on the gripper that arise during joining.



## ENERGY SUPPLY

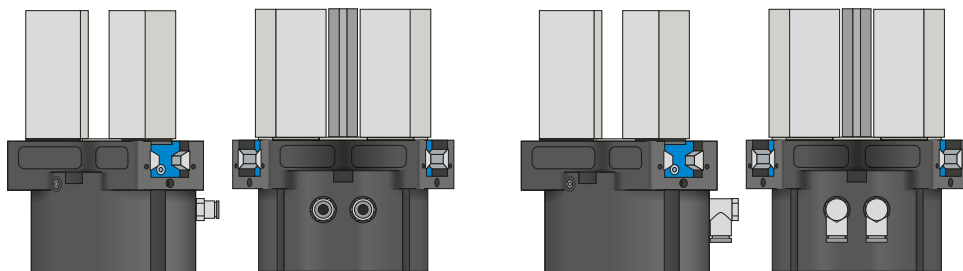

### Pneumatic threaded connections

Available in straight and angled design. Can be chosen freely depending on the space conditions or installation situation.

# 3-JAW CONCENTRIC GRIPPERS

## SERIES GPD5000 FUNCTIONAL DESCRIPTION



### ENERGY SUPPLY

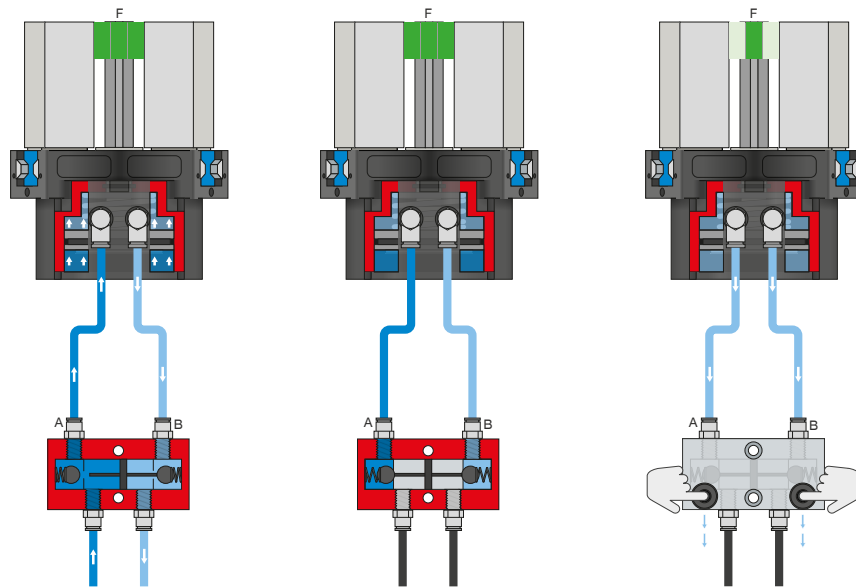

#### Pressure safety valve – DSV

Ensures safe retention of force and position if the system pressure drops

The integrated double check valve, which can be unlocked, retains the system pressure of the gripper in case of EMERGENCY STOP. To ensure the function, the valve must be installed as close to the gripper's air connection as possible. In variant E, two pushbuttons are installed that allow for controlled bleeding of the gripper.

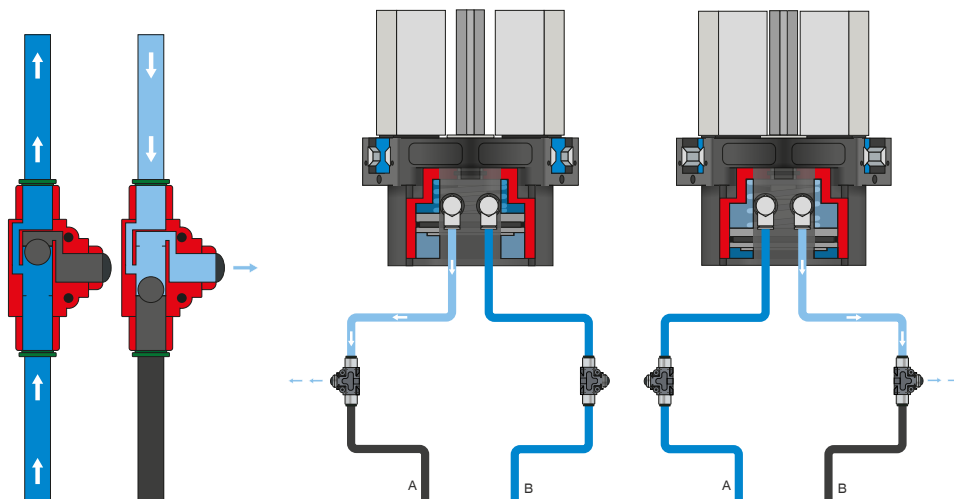

#### Quick exhaust valve – DEV

For rapid bleeding of the compressed air and preventing back pressure

The inline valves make a faster cycle time possible and prevent the formation of condensate in grippers with a small cylinder volume. To ensure the function, the valve must be installed as close to the gripper's air connection as possible.



## SENSORS

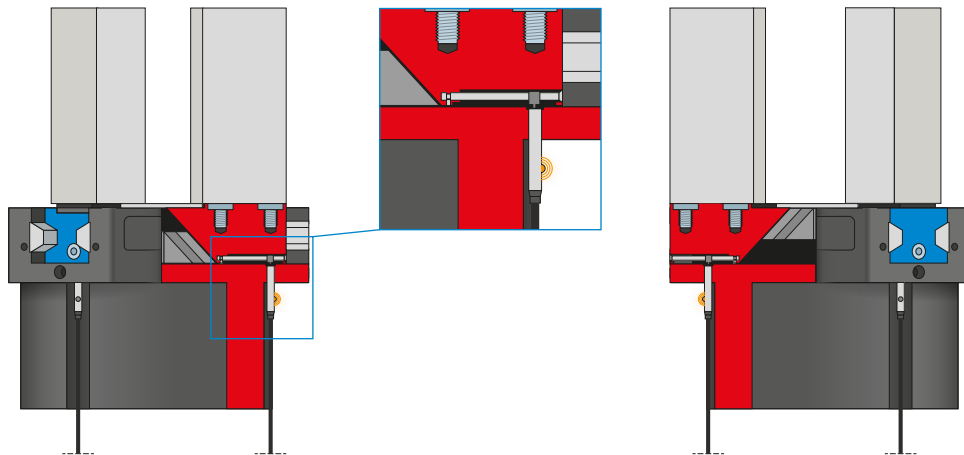

### Inductive sensors – NJ\*

#### For direct position sensing of the gripper jaws

The sensor is guided into the intake as far as it will go and fixed in place using the lateral clamping screw. Tuning to the desired position then takes place by adjusting the cam switch. The sensors are available in versions with 5 m cables with exposed leads and 0,3 m cable with connector, as well as with direct plug orientation.

\*Not for variant AL-A

# 3-JAW CONCENTRIC GRIPPERS

## SERIES GPD5000 FUNCTIONAL DESCRIPTION



### SENSORS

MFS02

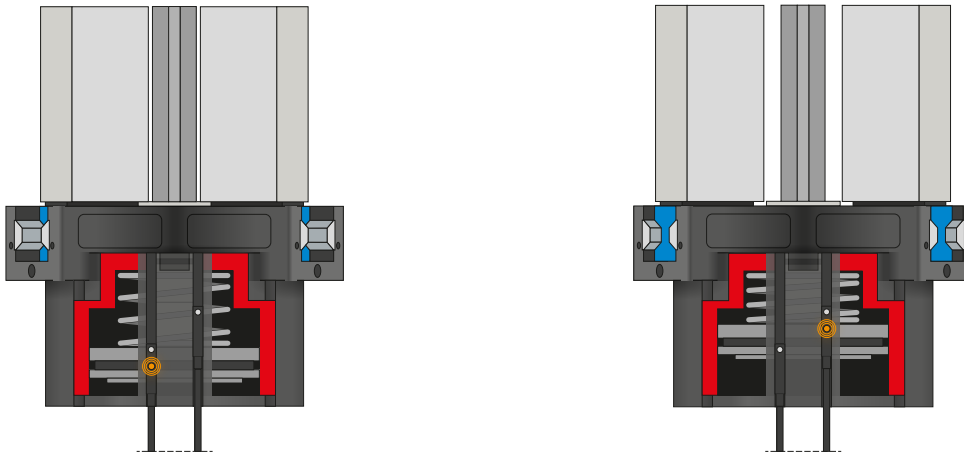

MFS01

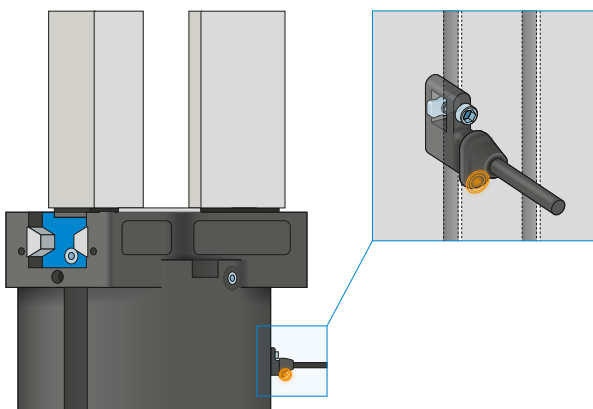

### 1-point magnetic field sensors – MFS

#### For non-contact sensing of the piston position

These sensors are installed in the C-groove of the gripper and detect the magnet attached to the piston of the gripper. To ensure use in a wide variety of space conditions, the sensors are available in two variants. While the horizontal MFS02, with straight cable outlet, disappears into the C-groove of the gripper almost completely, the vertical MFS01 is taller, but has a cable outlet that is offset at an angle of 90°. The variants are available in versions with 5 m cables with exposed leads and 0,3 m cable with connector.



## SENSORS

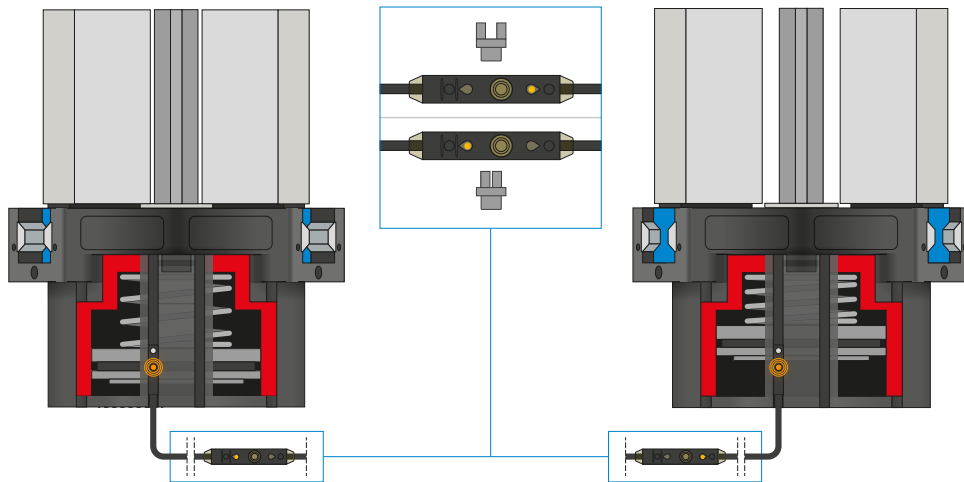

### 2-point magnetic field sensors - MFS

With two freely programmable switching points

Using the programming unit integrated in the cable, two switch points can be freely defined for this sensor. To do so, the sensor is clamped in the C-groove, the gripper approaches position one and the position is taught in using the teach button. Afterwards, the second position is approached with the gripper and programmed. To ensure use in a wide variety of space conditions, the sensors are available in two variants. While the horizontal MFS02, with straight cable outlet, disappears into the C-groove of the gripper almost completely, the vertical MFS01 is taller, but has a cable outlet that is offset at an angle of 90°. The sensors are available in versions with 5 m cables with exposed leads and 0,3 m cable with connector.



## CONNECTIONS / OTHER

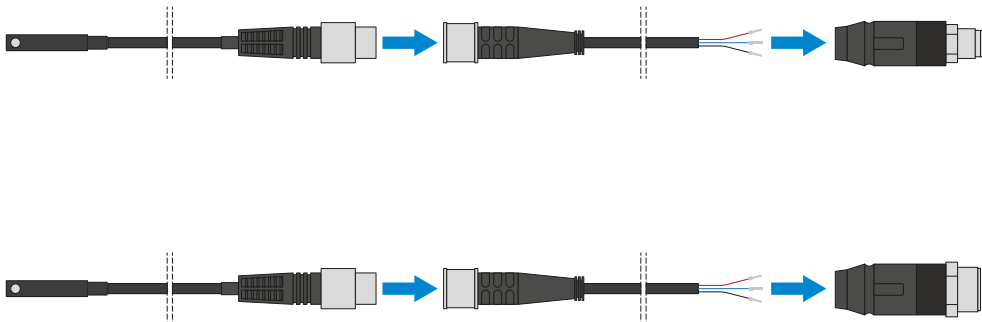

### Plug-in connectors

For extending and fabricating the connection lines for the sensors

Cables with a length of 5 m with exposed leads are available. Depending on the specific needs, the cables can be shortened or fabricated with connectors in sizes M8 and M12.

# 3-JAW CONCENTRIC GRIPPERS

## SERIES GPD5000 FUNCTIONAL DESCRIPTION



### CONNECTIONS / OTHER

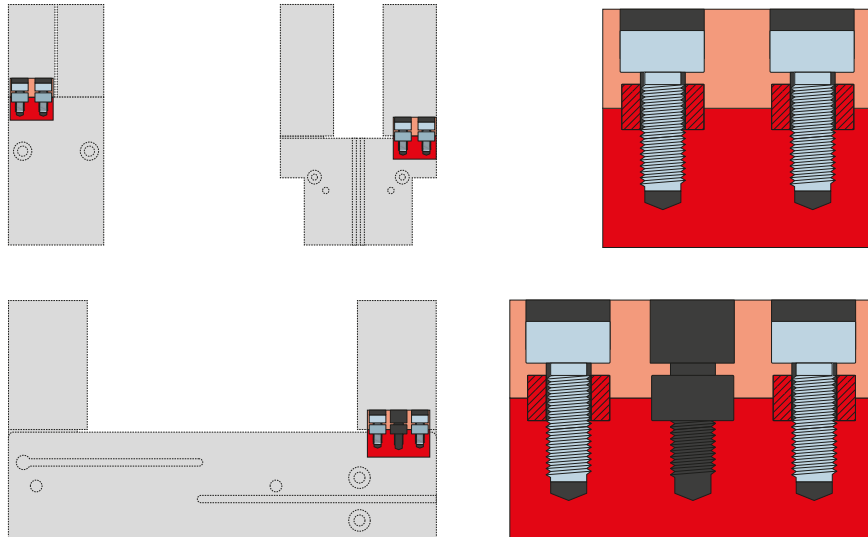

#### Centering sleeves

For defined position measurement of the gripper fingers

The centering sleeves are inserted into the fits of the gripper jaws to define the position of the gripper fingers. The centering sleeves are comparable to a pin connection.