

2-JAW PARALLEL GRIPPERS

SERIES GPP5000

▶ PRODUCT ADVANTAGES



“The best”

▶ **Steel Linear Guide – The superior guidance system concept**

The steel / steel guide stands for lasting precision, durability and a long service life—featuring maintenance intervals of up to 30 million gripping cycles. Benefit from these features and increase the profitability and process reliability of your machine.

▶ **Leakproof and corrosion protected – The universal gripper**

Suitable for virtually all ambient conditions, with a sealed guide up to IP67 and corrosion protection as standard, you are able to use this gripper universally. As a result, the range of models in your production is reduced, along with a reduction in associated storage and process costs.

▶ **Aluminum Linear Guide – The alternative**

Reduced to those aspects which are the most important, the steel / aluminum guide variant offers significantly better performance when compared to a similar gripper with a T-groove travel guide, and is on par with the best principles of toothed guidance systems.

▶ BENEFITS IN DETAIL

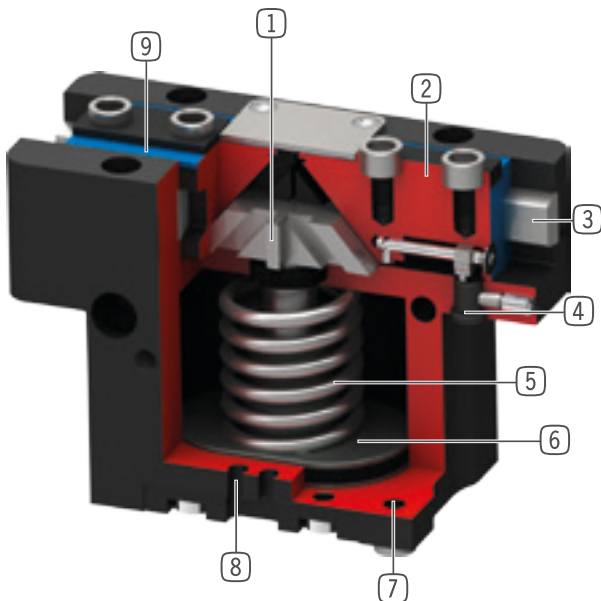

① **Wedge hook mechanism**

- Supports to absorb high forces and moments
- Synchronized gripper jaw movement

② **Gripper jaw**

- Gripper fingers mounted using removable centering sleeves
- Lubricated for life via incorporated lubrication slots

③ **Steel Linear Guide**

- Steel in steel guide
- Enables use of extremely long gripper fingers
- Also available in steel / aluminum variant

④ **Mounting block**

- mounting for inductive proximity switch

⑤ **Integrated gripping force safety device**

- Spring built into cylinder chamber as an energy store

⑥ **Drive**

- Double-acting pneumatic rotor cylinder

⑦ **Mounting and positioning**

- Alternatively, on several sides for customized mounting
- Pneumatic and electrical versions identical apart from height

⑧ **Sensing slot**

- mounting and positioning of magnetic field sensors

⑨ **Dual lip seal**

- IP64 and up to IP67 (with purged air) for Protector version
- Prevents grease from being squeezed out, increasing service life



► SERIES CHARACTERISTICS

Installation size		Variants				
GPP50XX		-00	-20	-21	-24	-AL
N	Long stroke	●	●	●	●	●
NC	Long stroke / Spring closing	●	●	●	●	●
NO	Long stroke / Spring opening	●	●	●	●	●
S	High-strength	●	●	●	●	
SC	High-strength / Spring closing	●	●	●	●	
SO	High-strength / Spring opening	●	●	●	●	
	Steel / steel guide	●	●	●	●	
	Steel / aluminum guide					●
	15 million maintenance-free cycles (max.)					●
	30 million maintenance-free cycles (max.)	●	●	●	●	
	Inductive sensor	●	●	●	●	
	Magnetic field sensor	●	●	●	●	●
	Protected against corrosion	●	●	●	●	
	Purged air	●	●	●	●	●
	Temperature-resistant		●		●	
	IP40					●
	IP64	●	●			
	IP67*			●	●	

*with purged air (max. 0,5 bar)

► TECHNICAL DATA

Installation size	Stroke per jaw [mm]	Gripping force [N]	Weight [kg]	IP class
GPP5003	2,5	140 - 205	0,08 - 0,12	IP40 / IP64 / IP67 *
GPP5004	2 - 4	200 - 630	0,15 - 0,3	IP40 / IP64 / IP67 *
GPP5006	3 - 6	330 - 1080	0,28 - 0,44	IP40 / IP64 / IP67 *
GPP5008	4 - 8	520 - 1670	0,53 - 0,76	IP40 / IP64 / IP67 *
GPP5010	5 - 10	885 - 2890	0,85 - 1,31	IP40 / IP64 / IP67 *
GPP5013	6 - 13	1410 - 4400	1,5 - 2,26	IP40 / IP64 / IP67 *
GPP5016	8 - 16	2090 - 6600	2,9 - 4,4	IP40 / IP64 / IP67 *
GPP5025	14 - 25	3280 - 9130	6,1 - 8,75	IP64 / IP67 *
GPP5030	17 - 30	5000 - 13550	9,2 - 13,7	IP64 / IP67 *
GPP5035	20 - 35	6100 - 15900	15,8 - 23,3	IP64 / IP67 *
GPP5045	26 - 45	10200 - 26950	33 - 50	IP64 / IP67 *

*with purged air (max. 0,5 bar)

2-JAW PARALLEL GRIPPERS

INSTALLATION SIZE GPP5016

▶ PRODUCT SPECIFICATIONS

-00-A / -20-A / -21-A / -24-A

Steel / steel guide

▶ Gripping force diagram

Shows the arithmetic total of the individual forces that occur on the gripper fingers, depending on the gripper finger length

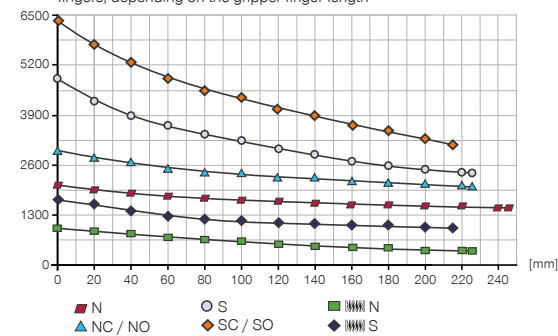

▶ Forces and moments

Displays static forces and moments that can also have an effect, besides the gripping force.

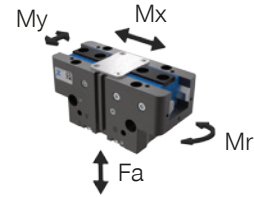

Mr [Nm]	145
Mx [Nm]	195
My [Nm]	185
Fa [N]	5200

-AL-A

Steel / aluminum guide

▶ Gripping force diagram

Shows the arithmetic total of the individual forces that occur on the gripper fingers, depending on the gripper finger length

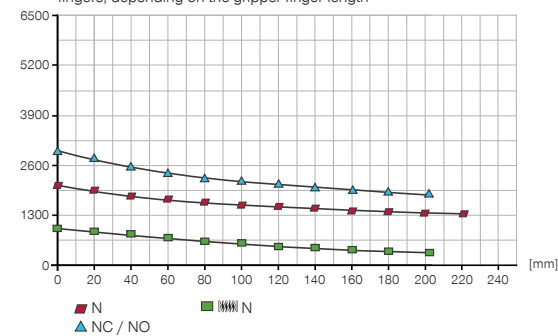

▶ Forces and moments

Displays static forces and moments that can also have an effect, besides the gripping force.

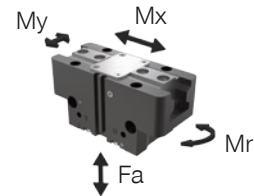

Mr [Nm]	140
Mx [Nm]	185
My [Nm]	180
Fa [N]	5000

▶ VARIANTS

-00-A / -20-A

Steel / steel guide

-21-A / -24-A

Steel / steel guide

-AL-A

Steel / aluminum guide



▶ TECHNICAL DATA

▶ Technical data

Order no.	GPP5016N-00-A	GPP5016NC-00-A	GPP5016NO-00-A	GPP5016S-00-A	GPP5016SC-00-A	GPP5016SO-00-A
Stroke per jaw [mm]	16	16	16	8	8	8
Gripping force in closing [N]	2090	2860		4610	6310	
Gripping force in opening [N]	2220		2990	4900		6600
Gripping force secured by spring min. [N]		770	770		1700	1700
Closing time [s]	0.13	0.11	0.24	0.13	0.11	0.24
Opening time [s]	0.13	0.24	0.11	0.13	0.24	0.11
Permissible weight per jaw max [kg]	3.8	3.8	3.8	3.8	3.8	3.8
Length of the gripper fingers max. [mm]	245	225	225	225	215	215
Repetition accuracy +/- [mm]	0.01	0.01	0.01	0.01	0.01	0.01
Operating pressure min. [bar]	3	4	4	3	4	4
Operating pressure max. [bar]	8	7	7	8	7	7
Nominal operating pressure [bar]	6	6	6	6	6	6
Operating temperature [°C]	-10 ... +90	-10 ... +90	-10 ... +90	-10 ... +90	-10 ... +90	-10 ... +90
Air volume per cycle [cm³]	166	332	332	166	332	332
Protection to IEC 60529	IP64	IP64	IP64	IP64	IP64	IP64
Protected against corrosion	Yes	Yes	Yes	Yes	Yes	Yes
Weight [kg]	2.9	3.7	3.7	2.9	3.7	3.7

▶ Technical Data - High Temperature Version

Order no.	GPP5016N-20-A	GPP5016NC-20-A	GPP5016NO-20-A	GPP5016S-20-A	GPP5016SC-20-A	GPP5016SO-20-A
Operating temperature [°C]	-10 ... +130	-10 ... +130	-10 ... +130	-10 ... +130	-10 ... +130	-10 ... +130

▶ Technical Data - Protector Version

Order no.	GPP5016N-21-A	GPP5016NC-21-A	GPP5016NO-21-A	GPP5016S-21-A	GPP5016SC-21-A	GPP5016SO-21-A
Protection to IEC 60529	IP67*	IP67*	IP67*	IP67*	IP67*	IP67*
Weight [kg]	3.6	4.4	4.4	3.6	4.4	4.4

▶ Technical Data - High Temperature Protector Version

Order no.	GPP5016N-24-A	GPP5016NC-24-A	GPP5016NO-24-A	GPP5016S-24-A	GPP5016SC-24-A	GPP5016SO-24-A
Operating temperature [°C]	-10 ... +130	-10 ... +130	-10 ... +130	-10 ... +130	-10 ... +130	-10 ... +130
Protection to IEC 60529	IP67*	IP67*	IP67*	IP67*	IP67*	IP67*
Weight [kg]	3.6	4.4	4.4	3.6	4.4	4.4

*with purged air (max. 0,5 bar)

▶ Technical data

Order no.	GPP5016N-AL-A	GPP5016NC-AL-A	GPP5016NO-AL-A
Permissible weight per jaw max [kg]	3.5	3.5	3.5
Length of the gripper fingers max. ** [mm]	215	210	210
IP class	IP40	IP40	IP40
Protected against corrosion	No	No	No
Weight [kg]	2.9	3.6	3.6

▶ Maximum gripper finger length

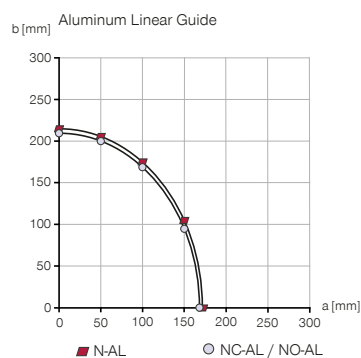
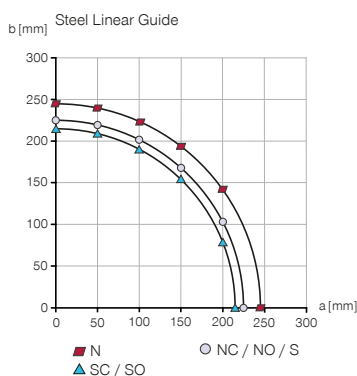

▶ Resulting gripper finger length for determining the gripping force

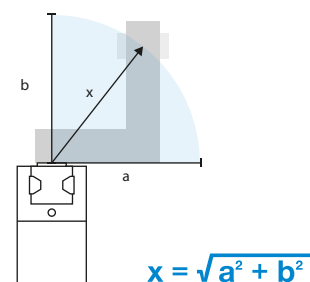

2-JAW PARALLEL GRIPPERS

INSTALLATION SIZE GPP5016

TECHNICAL DRAWINGS

NC / NO / SC / SO
-00-A / -20-A / -AL-A

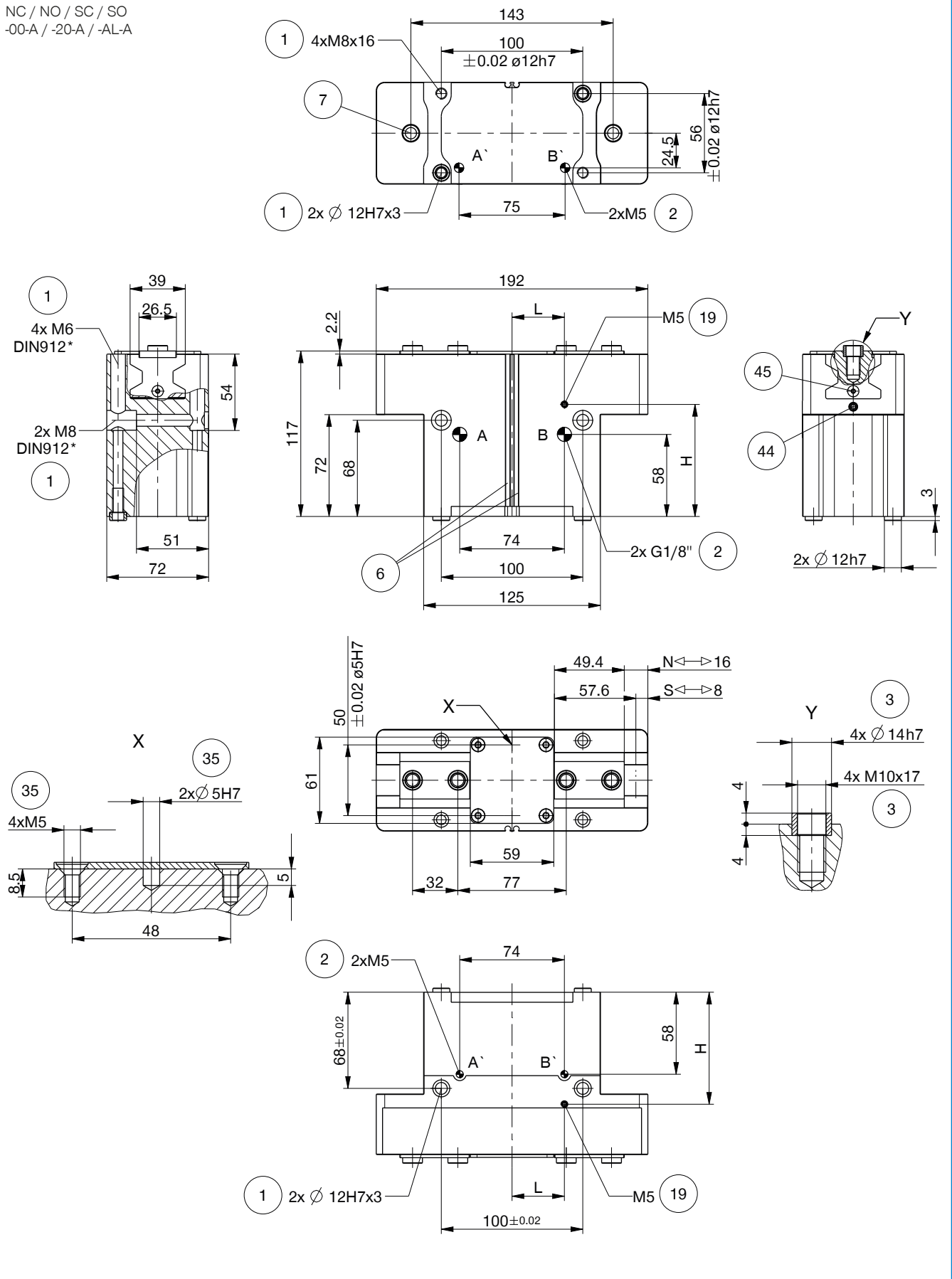

▶ TECHNICAL DRAWINGS

N / S
-00-A / -20-A / -AL-A

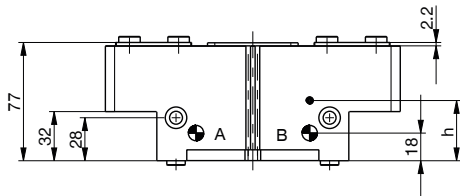

N / NC / NO / S / SC / SO
-21-A / -24-A

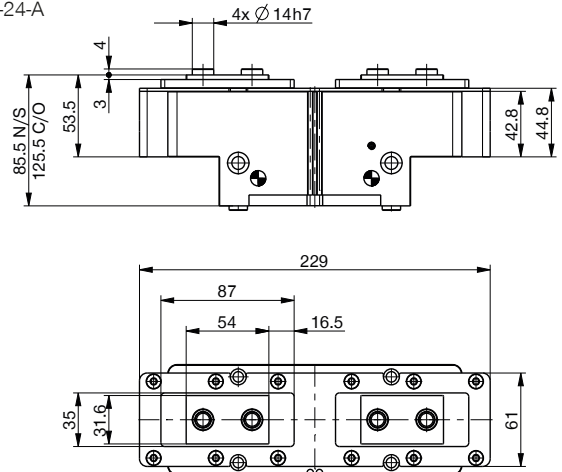

Hoseless air feed-through M5

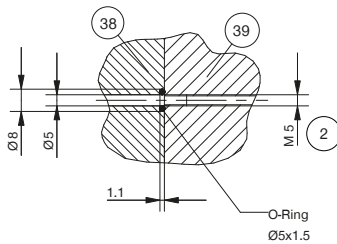

- ① Gripper attachment
- ② Energy supply
- ③ Fixing for gripper finger
- ⑥ Integrated slot for magnetic field sensor
- ⑦ Mounting block (not for variant AL-A)
- ⑰ Air purge connection option (max. 0,5 bar)
- ⑳ Attachment option for customer-specific fittings
- ㉘ Adapter
- ㉙ Gripper
- ㉚ Clamping sensor (not for variant AL-A)
- ㉛ Switch cam adjustment (not for variant AL-A)
- Ⓐ Air connection (close)
- Ⓑ Air connection (open)
- Ⓐ Air connection, alternative (close)
- Ⓑ Air connection, alternative (open)

▶ Position ⑰ sealing air connection option

Order no.	-00-A / -20-A / -21-A / -24-A	-AL-A
H [mm]	79.2	99.1
L [mm]	37	10
h [mm]	39.2	59.1



2-JAW PARALLEL GRIPPERS

INSTALLATION SIZE GPP5016

▶ ACCESORIES

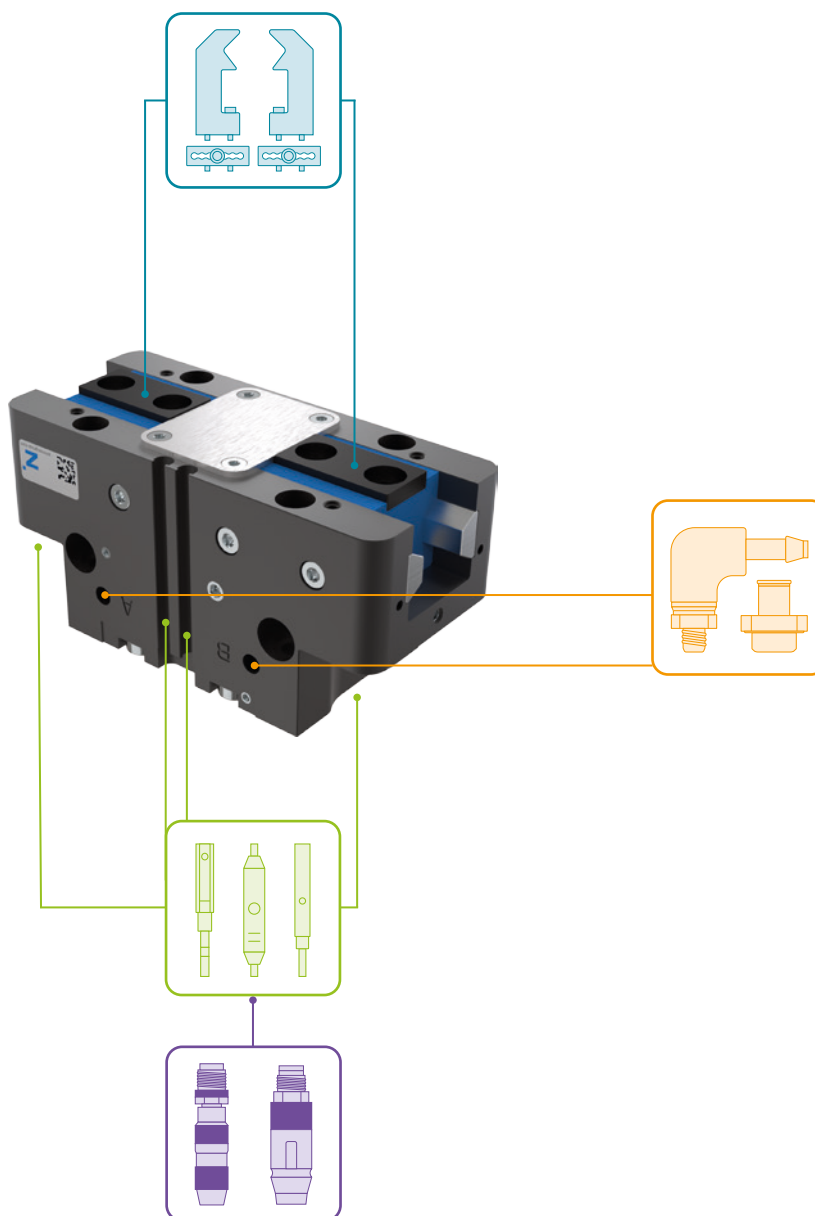

▶ INCLUDED IN DELIVERY



4 [piece]
Centering Disc

019387

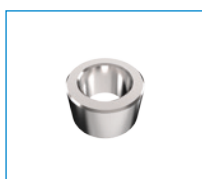

2 [piece]
Centering Disc

019280

▶ RECOMMENDED ACCESSORIES



GRIPPING COMPONENTS

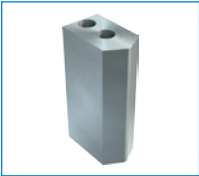

UB5016AL
Universal jaw aluminium



UB5016ST
Universal jaw steel



EB5016AL
Aluminum adjustment jaw

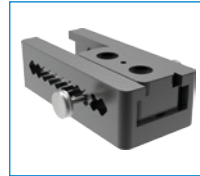

EB5016ST
Steel adjustment jaw

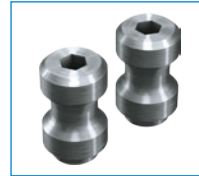

WB5016L
Changeable jaw, loose-part-set

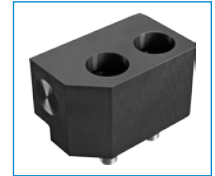

WB5016F
Changeable jaw, fix-part



ENERGY SUPPLY



WV1-8X8
Angled Fittings - Quick Connect Style



DEV08
Quick Exhaust Valve



DSV1-8
Pressure safety valve

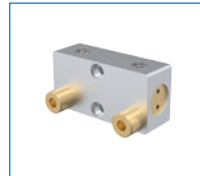

DSV1-8E
Pressure safety valve with quick exhaust



SENSORS



NJ8-E2S
Inductive proximity switch - Connector M8

*Not for variant AL-A

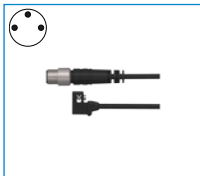

MFS01-S-KHC-P1-PNP
Magnetic field sensor angled, cable 0.3 m - M8 connector



MFS02-S-KHC-P1-PNP
Magnetic field sensor straight, cable 0.3 m - M8 connector



MFS01-S-KHC-P2-PNP
2-point sensor angled, cable 0.3 m - M8 connector

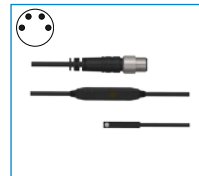

MFS02-S-KHC-P2-PNP
2-point sensor straight, cable 0.3 m - M8 connector



CONNECTIONS / OTHER

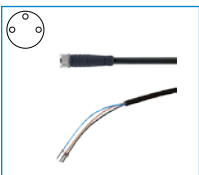

KAG500
Plug-in connector Straight Cable 5m - Socket M8 (female)



S8-G-3
Plug-in connector customizable Straight - Connector M8

2-JAW PARALLEL GRIPPERS

SERIES GPP5000 FUNCTIONAL DESCRIPTION



GRIPPING COMPONENTS

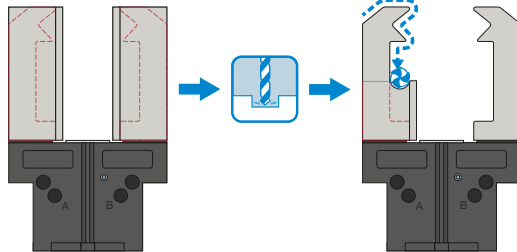

Universal jaws – UB5000

Can be used immediately or for individual reprocessing

The gripper blanks are available in aluminum (AL) and steel (ST) versions and are installed directly on the gripper using the screws in the scope of delivery. The fits for the centering sleeves are already in place for this purpose. One universal jaw is required for each gripper jaw.

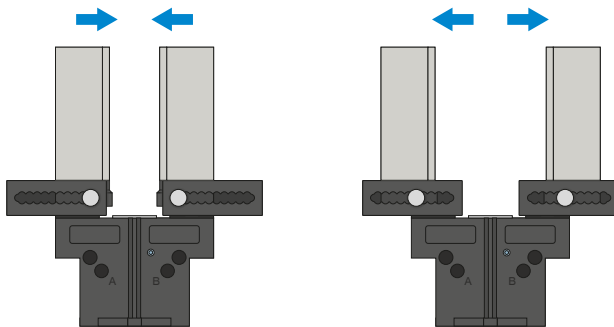

Adjustment jaws – EB5000

For tool-free adaptation of the gripper range

By manually activating the locking mechanism, which is pre-tensioned by a spring, the adjustment jaw can be moved within a grid of detent notches that has a number scale. Depending on the forces and torques that apply, the adjustment jaws are available in aluminum (AL) and steel (ST) versions. One adjustment jaw is required for each gripper jaw.

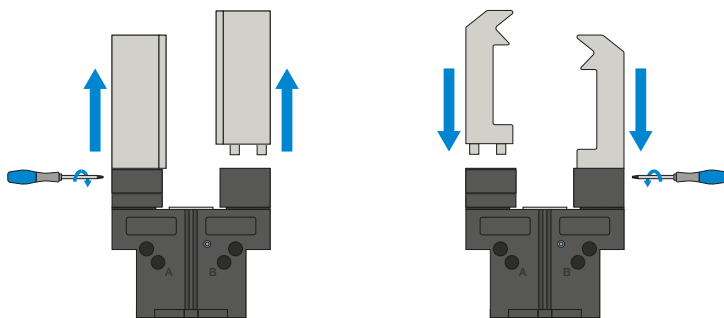

Interchangeable jaws – WB5000

Enable fast change of individual gripper fingers

For each gripper jaw, a fixed part and at least one loose part set is needed, depending on the number of gripper fingers to be changed. Manual locking via the Torx wrench included in the scope of delivery of the fixed part can take place from two sides.



THE GRIPPING COMPONENTS CAN BE COMBINED!

The gripper components listed above can be combined with each other and are compatible with the various series of the 5000 gripper family.



ENERGY SUPPLY

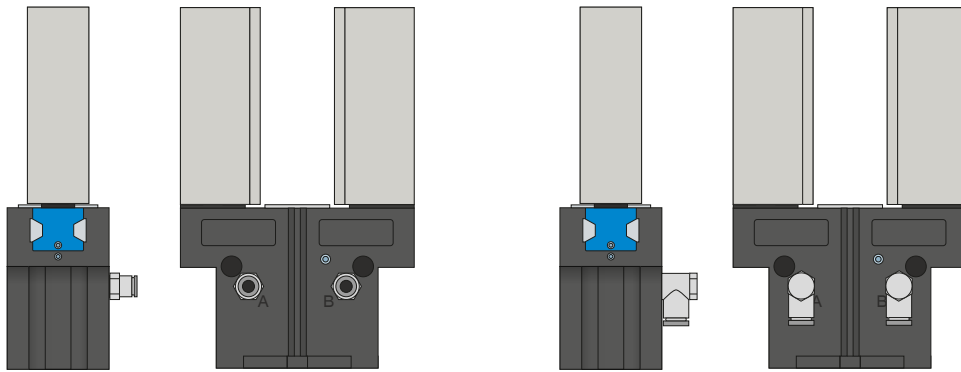

Pneumatic threaded connections

Available in straight and angled design. Can be chosen freely depending on the space conditions or installation situation.

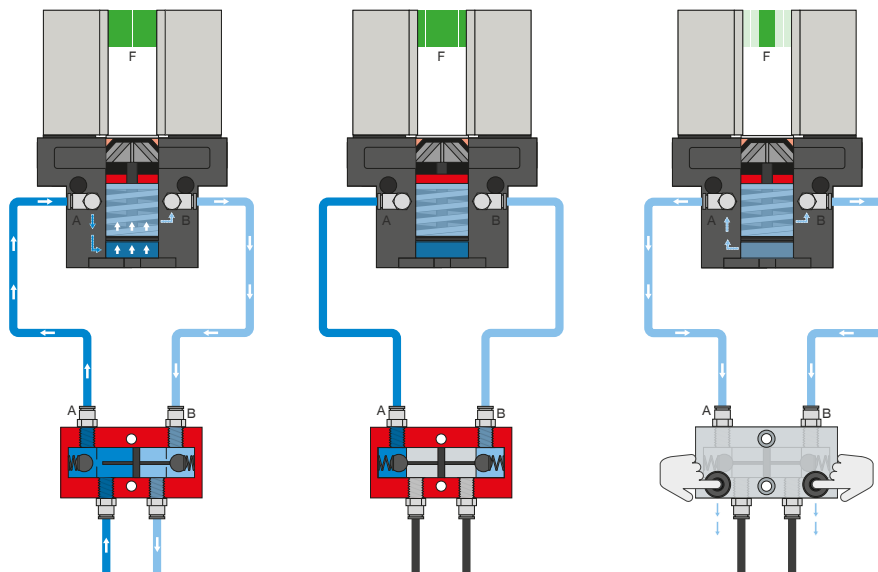

Pressure safety valve – DSV

Ensures safe retention of force and position if the system pressure drops

The integrated double check valve, which can be unlocked, retains the system pressure of the gripper in case of EMERGENCY STOP. To ensure the function, the valve must be installed as close to the gripper's air connection as possible. In variant E, two pushbuttons are installed that allow for controlled bleeding of the gripper.

2-JAW PARALLEL GRIPPERS

SERIES GPP5000 FUNCTIONAL DESCRIPTION



ENERGY SUPPLY

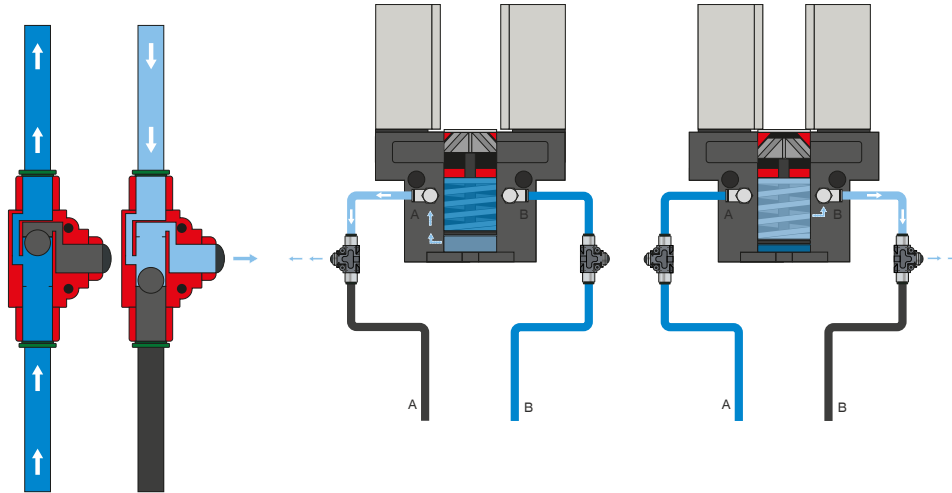

Quick exhaust valve – DEV

For rapid bleeding of the compressed air and preventing back pressure

The inline valves make a faster cycle time possible and prevent the formation of condensate in grippers with a small cylinder volume. To ensure the function, the valve must be installed as close to the gripper's air connection as possible.



SENSORS

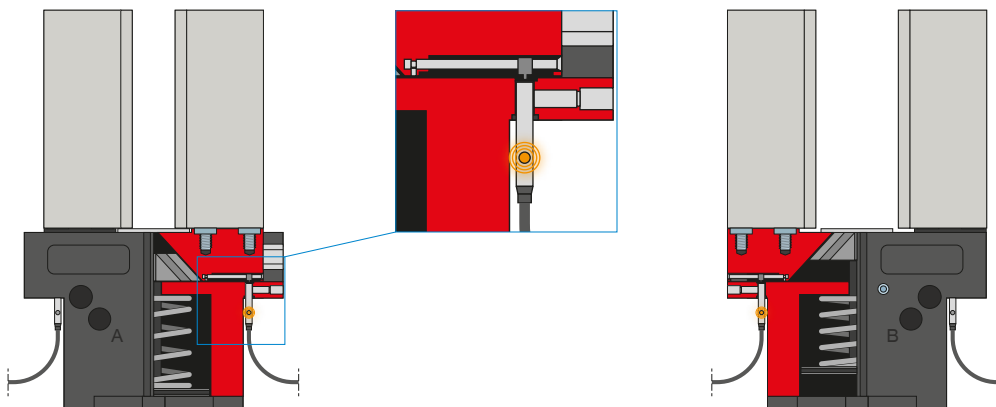

Inductive sensors – NJ*

For direct position sensing of the gripper jaws

The sensor is guided into the intake as far as it will go and fixed in place using the lateral clamping screw. Tuning to the desired position then takes place by adjusting the cam switch. The sensors are available in versions with 5 m cables with exposed leads and 0,3 m cable with connector, as well as with direct plug orientation.

*Not for variant AL-A



SENSORS

MFS02

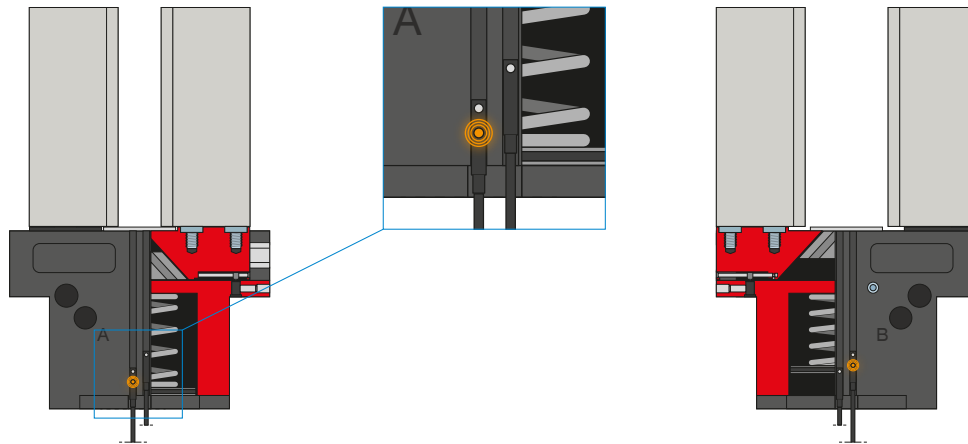

MFS01

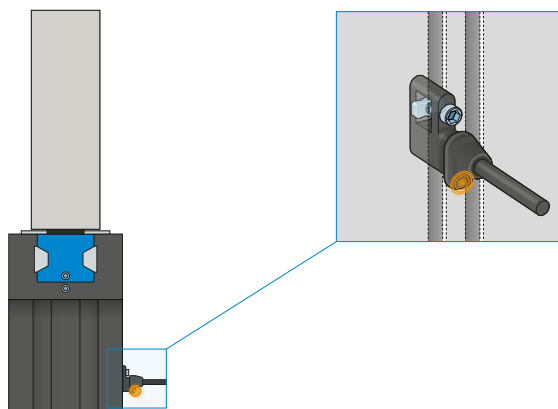

1-point magnetic field sensors – MFS

For non-contact sensing of the piston position

These sensors are installed in the C-groove of the gripper and detect the magnet attached to the piston of the gripper. To ensure use in a wide variety of space conditions, the sensors are available in two variants. While the horizontal MFS02, with straight cable outlet, disappears into the C-groove of the gripper almost completely, the vertical MFS01 is taller, but has a cable outlet that is offset at an angle of 90°. The variants are available in versions with 5 m cables with exposed leads and 0,3 m cable with connector.

2-JAW PARALLEL GRIPPERS

SERIES GPP5000 FUNCTIONAL DESCRIPTION



SENSORS

MFS02

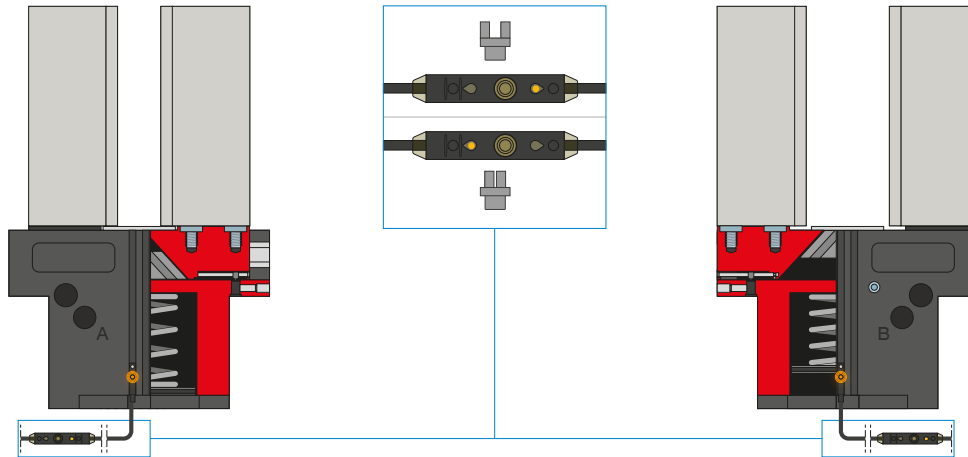

2-point magnetic field sensors - MFS

With two freely programmable switching points

Using the programming unit integrated in the cable, two switch points can be freely defined for this sensor. To do so, the sensor is clamped in the C-groove, the gripper approaches position one and the position is taught in using the teach button. Afterwards, the second position is approached with the gripper and programmed. To ensure use in a wide variety of space conditions, the sensors are available in two variants. While the horizontal MFS02, with straight cable outlet, disappears into the C-groove of the gripper almost completely, the vertical MFS01 is taller, but has a cable outlet that is offset at an angle of 90°. The sensors are available in versions with 5 m cables with exposed leads and 0,3 m cable with connector.



CONNECTIONS / OTHER

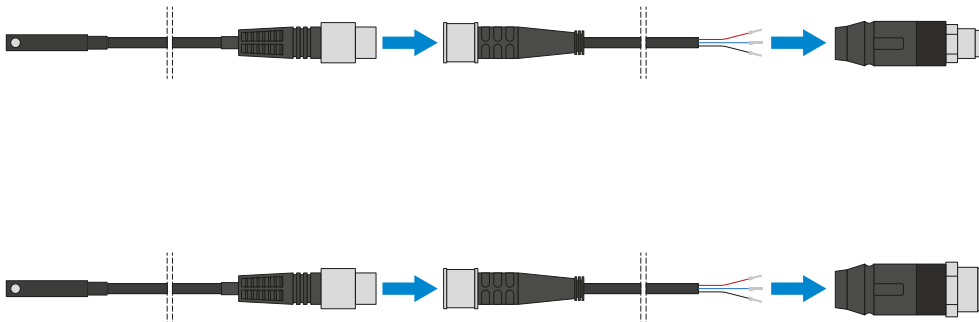

Plug-in connectors

For extending and fabricating the connection lines for the sensors

Cables with a length of 5 m with exposed leads are available. Depending on the specific needs, the cables can be shortened or fabricated with connectors in sizes M8 and M12.



CONNECTIONS / OTHER

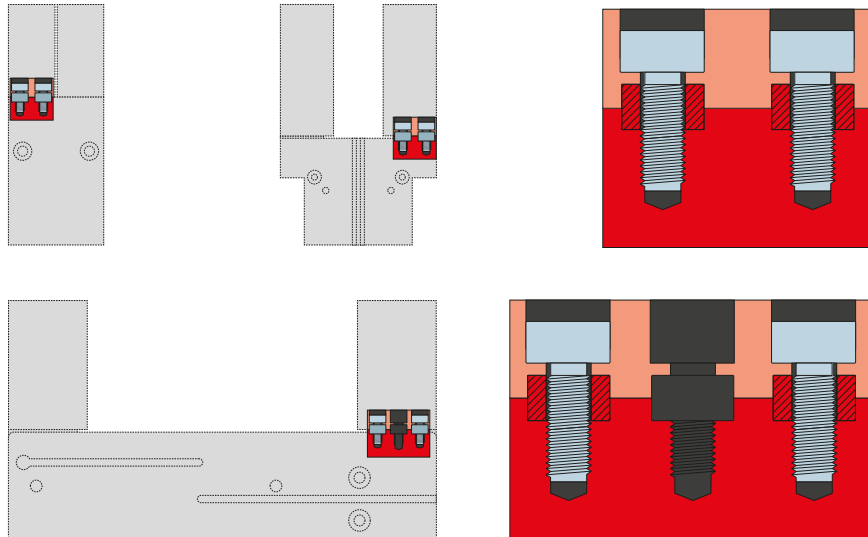

Centering sleeves

For defined position measurement of the gripper fingers

The centering sleeves are inserted into the fits of the gripper jaws to define the position of the gripper fingers. The centering sleeves are comparable to a pin connection.

2-JAW PARALLEL GRIPPERS

SERIES GPP5000 GRIPPER FINGER LENGTH



MAXIMUM GRIPPER FINGER LENGTH

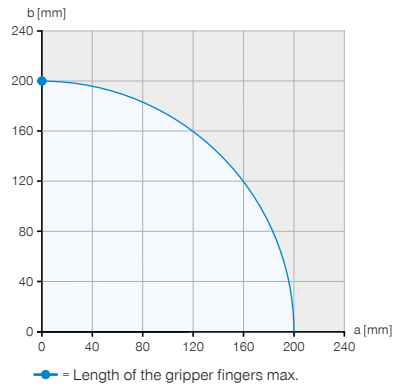
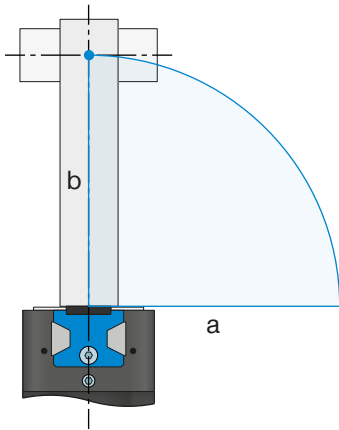

Example 1

Vertical force application point

$a = 0 \text{ mm}$

$b = 200 \text{ mm}$

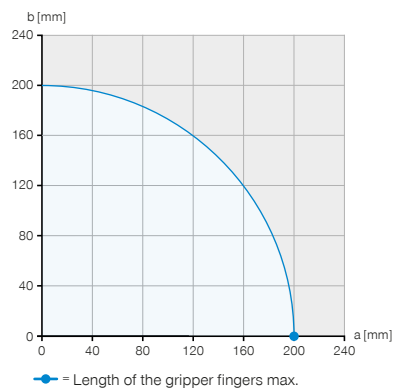
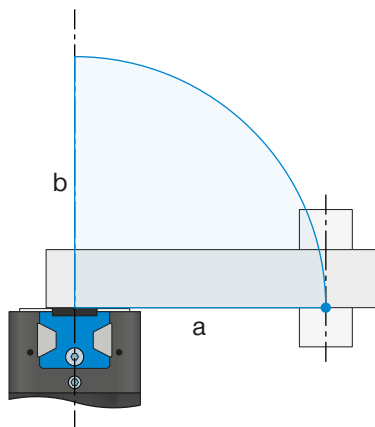

Example 2

Horizontal force application point

$a = 200 \text{ mm}$

$b = 0 \text{ mm}$

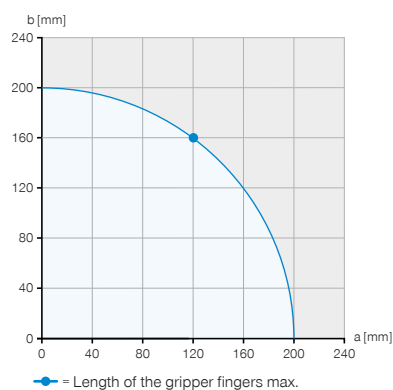
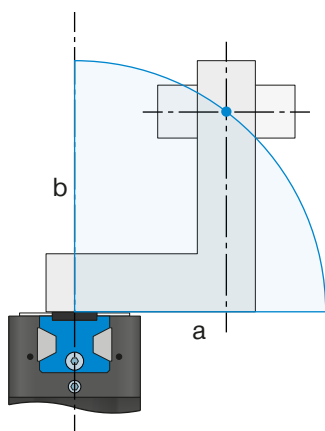

Example 3

Maximum permissible projection

$a = 120 \text{ mm}$

$b = 160 \text{ mm}$

The examples show the maximum horizontal (a) and vertical (b) gripper finger length using the example of a GPP5013N-00-A, which is represented by the blue area.



GRIPPING FORCE AS A FUNCTION OF GRIPPER FINGER LENGTH

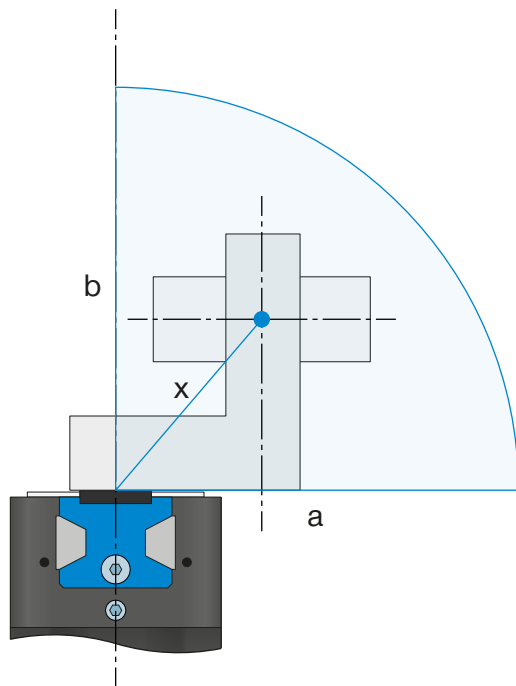

► Gripping force diagram

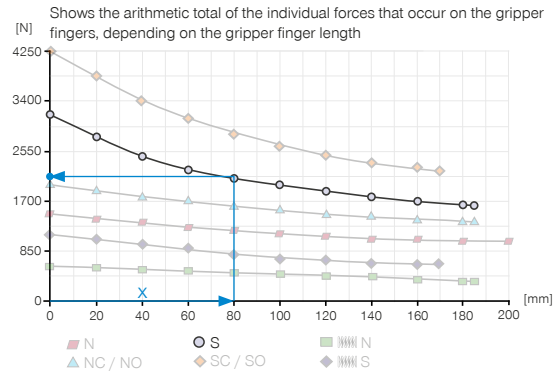

Example 4

Resulting gripper finger length for determining the gripping force

a = 55 mm

b = 58 mm

$$x = \sqrt{55^2 + 58^2} = 80 \Rightarrow 2125 \text{ N}$$



GUIDE CHARACTERISTICS

Steel / aluminum guide and steel / steel guide in comparison

In general, the maximum possible length of gripper fingers of a steel / aluminum guide is lower in comparison to the steel / steel guide, due to the lower yield point of aluminum. While the maximum gripper finger length in the horizontal (a) and vertical (b) direction can be fully utilized for the steel / steel guide, the maximum gripper finger length that is specified in the technical data for the steel / aluminum guide is reduced by 20% at a horizontal (a) projection. The lower efficiency of a steel / aluminum guide also leads to a higher decrease in gripping force at an increased gripping finger length and to a reduction in service life as a result of a lower resistance to wear.

Steel / aluminum guide

Steel / aluminum guides are very common worldwide. They are available in many different forms and are installed in virtually all commercially available grippers from an extremely wide variety of manufacturers. The steel / aluminum grippers from Zimmer Group are available as AL variants of the tried-and-tested 5000 Series. Their designs are geared toward the important aspects and they are very cost-effective.

Steel / steel guide

Steel / steel guides are the best and first choice wherever durability and robustness are essential. The Steel Linear Guide from Zimmer Group is also clearly distinguished from a steel / aluminum guide thanks to its exclusive design featuring higher material characteristics.

Steel Linear Guide – Added value in detail

- + Steel in steel guide
- + IP64 and up to IP67 (with sealing air) in the protector version
- + Corrosion protected
- + Up to 30 million maintenance-free cycles (max.)