

INTERNAL GRIPPER

SERIES LGG

▶ PRODUCT ADVANTAGES



▶ Surface protection with rubber knobs

Continuously protect the surface of your workpieces and minimise rejections in the process

▶ Secure hold

The coefficient of friction ensures your workpiece stays held reliably, even under high dynamics

▶ Direct drive

The control system with only one pneumatic line reduces installation effort and interference contours

▶ SERIES CHARACTERISTICS

Installation size

LGXX-XX



Maintenance free



IP54





► BENEFITS IN DETAIL

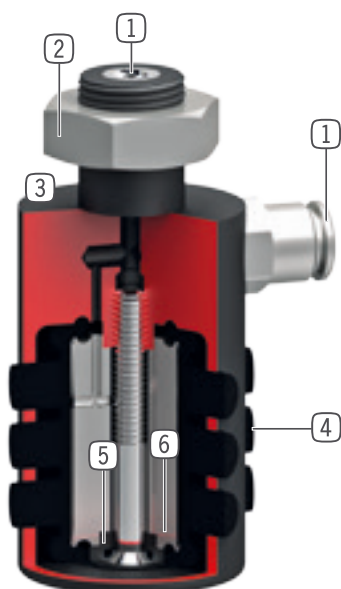

- 1 Energy supply**
 - radial
 - axial and radial from LG35-39
- 2 Fixing**
 - by fit, thread and locknut
- 3 Robust, lightweight housing**
 - Hard-coated aluminum alloy
 - no overstretching of the rubber membrane at empty stroke
- 4 Direct gripping with rubber knops**
 - high retention force due to good friction value, approx. 0.5 with rubber
- 5 Gripping with single-acting rubber membranes**
 - low actuate effort
 - reset when venting
 - adjustable force with operating pressure (2 - 6 bar)
- 6 Inner core**
 - saves air volume and cycle time (from LG35-39)

► TECHNICAL DATA

Installation size	Total stroke in Ø [mm]	Gripping force [N]	Weight [kg]	IP class
LG15-18	2.5	100	0.031	IP54
LG18-22	4	100	0.035	IP54
LG22-26	4	150	0.051	IP54
LG26-30	4	150	0.071	IP54
LG30-35	5	200	0.09	IP54
LG35-39	4.5	300	0.13	IP54
LG40-45	6.5	400	0.178	IP54
LG46-51	6	500	0.26	IP54
LG51-56	7	750	0.37	IP54
LG56-62	7.5	900	0.373	IP54
LG63-70	8	1100	0.53	IP54
LG71-80	10.5	1500	0.69	IP54
LG76-84	8.5	1700	0.8	IP54
LG81-90	11	2000	1	IP54
LG91-100	10	2500	1.3	IP54
LG100-110	11	2800	1.9	IP54
LG110-120	11	3500	2.3	IP54
LG120-135	16	3500	2.7	IP54

INTERNAL GRIPPER

SERIES LGG

▶ PRODUCT SPECIFICATIONS

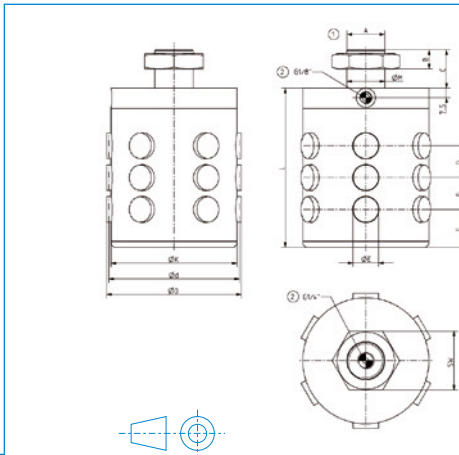

- ① Gripper attachment
- ② Energy supply

▶ RECOMMENDED ACCESSORIES



ENERGY SUPPLY



GV1-8X8
Straight Fittings - Quick Connect Style



ENERGY SUPPLY



DEV06
Quick Exhaust Valve

Order no.	▶ Technical data		
	LG100-110	LG110-120	LG120-135
Total stroke in Ø [mm]	11	11	16
Clamping diameter d min. [mm]	99.5	109.5	119.5
Clamping diameter D max. [mm]	110.5	120.5	135.5
Gripping force in extraction [N]	2800	3500	3500
Retract time / Extend time [s]	0.4	0.4	0.4
Repetition accuracy +/- [mm]	0.05	0.05	0.05
Operating pressure min. [bar]	2	2	2
Operating pressure max. [bar]	6	6	6
Nominal operating pressure [bar]	6	6	6
Operating temperature min. [°C]	5	5	5
Operating temperature max. [°C]	+80	+80	+80
Air volume per cycle [cm³]	150	200	250
Weight [kg]	1.9	2.3	2.7
A	M30X1.5	M30X1.5	M30X1.5
C [mm]	30	30	30
E Ø [mm]	20	22	22
F [mm]	30	31	37
G [mm]	25	25	28
K Ø [mm]	99	109	119
L [mm]	120	130	145
M Ø [mm]	30h7	30h7	30h7