

# INTERNAL GRIPPER

## SERIES LGG

### ▶ PRODUCT ADVANTAGES



#### ▶ Surface protection with rubber knobs

Continuously protect the surface of your workpieces and minimise rejections in the process

#### ▶ Secure hold

The coefficient of friction ensures your workpiece stays held reliably, even under high dynamics

#### ▶ Direct drive

The control system with only one pneumatic line reduces installation effort and interference contours

### ▶ SERIES CHARACTERISTICS

Installation size

LGXX-XX



Maintenance free



IP54





## ► BENEFITS IN DETAIL

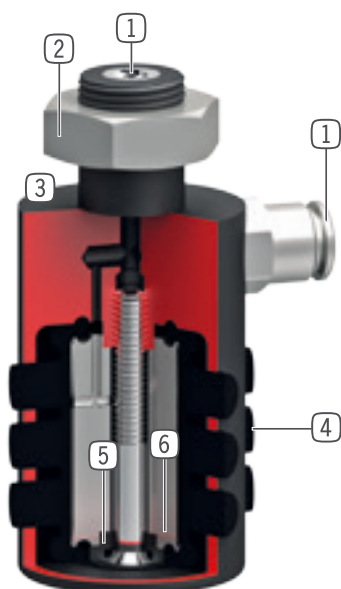

- 1 Energy supply**
  - radial
  - axial and radial from LG35-39
- 2 Fixing**
  - by fit, thread and locknut
- 3 Robust, lightweight housing**
  - Hard-coated aluminum alloy
  - no overstretching of the rubber membrane at empty stroke
- 4 Direct gripping with rubber knops**
  - high retention force due to good friction value, approx. 0.5 with rubber
- 5 Gripping with single-acting rubber membranes**
  - low actuate effort
  - reset when venting
  - adjustable force with operating pressure (2 - 6 bar)
- 6 Inner core**
  - saves air volume and cycle time (from LG35-39)

## ► TECHNICAL DATA

Installation size	Total stroke in Ø [mm]	Gripping force [N]	Weight [kg]	IP class
LG15-18	2.5	100	0.031	IP54
LG18-22	4	100	0.035	IP54
LG22-26	4	150	0.051	IP54
LG26-30	4	150	0.071	IP54
LG30-35	5	200	0.09	IP54
LG35-39	4.5	300	0.13	IP54
LG40-45	6.5	400	0.178	IP54
LG46-51	6	500	0.26	IP54
LG51-56	7	750	0.37	IP54
LG56-62	7.5	900	0.373	IP54
LG63-70	8	1100	0.53	IP54
LG71-80	10.5	1500	0.69	IP54
LG76-84	8.5	1700	0.8	IP54
LG81-90	11	2000	1	IP54
LG91-100	10	2500	1.3	IP54
LG100-110	11	2800	1.9	IP54
LG110-120	11	3500	2.3	IP54
LG120-135	16	3500	2.7	IP54

# INTERNAL GRIPPER SERIES LGG

## ▶ PRODUCT SPECIFICATIONS

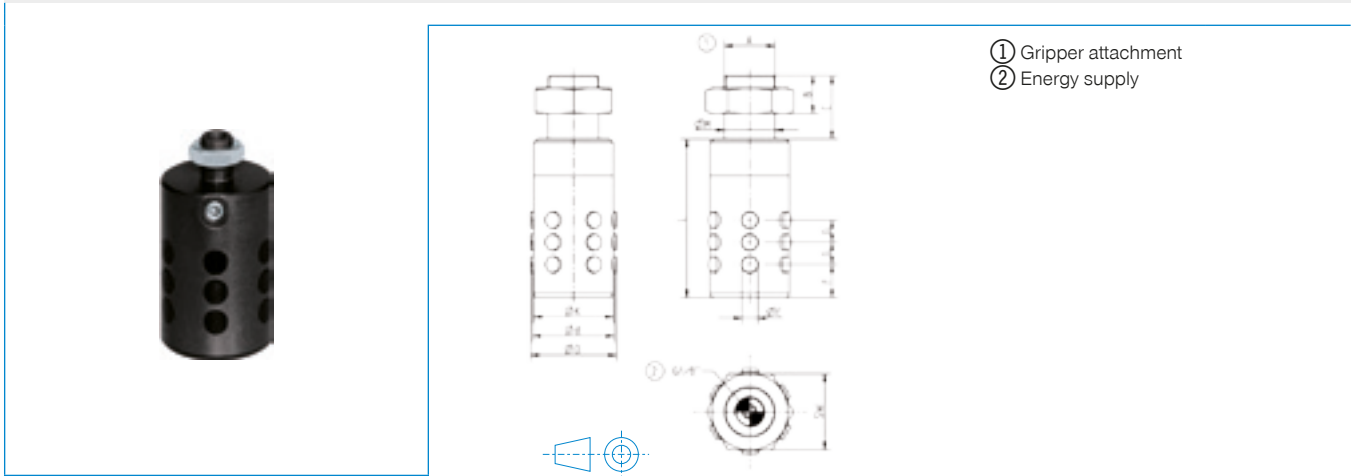

## ▶ RECOMMENDED ACCESSORIES



### ENERGY SUPPLY



**GV1-8X8**  
Straight Fittings - Quick Connect Style



### ENERGY SUPPLY



**DEV06**  
Quick Exhaust Valve

Order no.	▶ Technical data				
	LG15-18	LG18-22	LG22-26	LG26-30	LG30-35
Total stroke in Ø [mm]	2.5	4	4	4	5
Clamping diameter d min. [mm]	15	17.5	21.5	25.5	29.5
Clamping diameter D max. [mm]	17.5	21.5	25.5	29.5	34.5
Gripping force in extraction [N]	100	100	150	150	200
Retract time / Extend time [s]	0.2	0.2	0.2	0.2	0.2
Repetition accuracy +/- [mm]	0.05	0.05	0.05	0.05	0.05
Operating pressure min. [bar]	2	2	2	2	2
Operating pressure max. [bar]	6	6	6	6	6
Nominal operating pressure [bar]	6	6	6	6	6
Operating temperature min. [°C]	5	5	5	5	5
Operating temperature max. [°C]	+80	+80	+80	+80	+80
Air volume per cycle [cm³]	1	1	1	2	3
Weight [kg]	0.031	0.035	0.051	0.071	0.09
A	M14X1.5	M14X1.5	M14X1.5	M16X1	M16X1
C [mm]	18	18	20	20	20
E Ø [mm]	5	5	5	6	7
F [mm]	10.5	10.5	11.5	10.5	11.5
G [mm]	7	7	7	7	8
K Ø [mm]	14.5	17	21	25	29
L [mm]	42	42	50	50	52
M Ø [mm]	14h7	14h7	14h7	16h7	16h7